

YAMAHA

MEP4

MIDI EVENT PROCESSOR

OWNER'S MANUAL

SUPPLEMENTAL MARKING INFORMATION

Yamaha Digital Musical Instrument Products will have either a label similar to the graphic shown below or a molded/stamped facsimile of the graphic on its enclosure. The explanation of these graphics appears on this page. Please observe all cautions indicated.

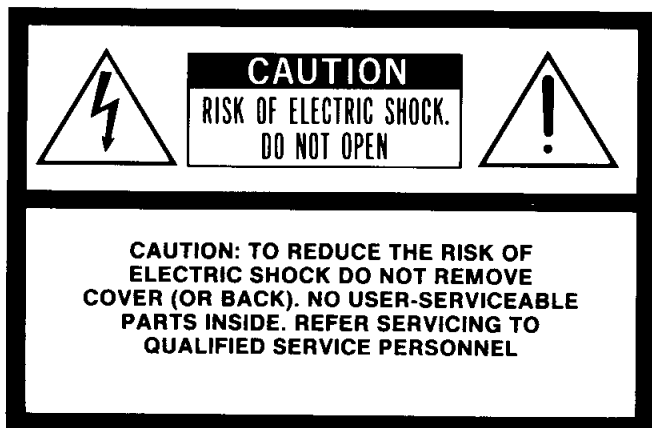

The Exclamation point within an equilateral triangle is intended to alert the user to the presence of important operating and maintenance (servicing) instructions in the literature accompanying the product.



The lightning flash with arrowhead symbol, within an equilateral triangle, is intended to alert the user to the presence of uninsulated "dangerous voltage" within the product's enclosure that may be of sufficient magnitude to constitute a risk of electric shock to persons.

SPECIAL MESSAGE SECTION

ELECTROMAGNETIC INTERFERENCE (RFI): Your Yamaha Digital Musical Instrument Product has been type tested and found to comply with all applicable regulations. However, if it is installed in the immediate proximity of other electronic devices, some form of interference may occur. For additional RFI information see FCC information section located in this manual.

IMPORTANT NOTICE: This product has been tested and approved by independent safety testing laboratories in order that you may be sure that when it is properly installed and used in its normal and customary manner, all foreseeable risks have been eliminated. DO NOT modify this unit or commission others to do so unless specifically authorized by Yamaha. Product performance and/or safety standards may be diminished. Claims filed under the expressed warranty may be denied if the unit is/has been modified. Implied warranties may also be affected.

SPECIFICATIONS SUBJECT TO CHANGE: The information contained in this manual is believed to be correct at the time of printing. Yamaha reserves the right to change or modify specifications at any time without notice or obligation to update existing units.

NOTICE: Service charges incurred due to a lack of knowledge relating to how a function or effect works (when the unit is operating as designed), are not covered by the manufacturer's warranty. Please study this manual carefully before requesting service.

STATIC ELECTRICITY CAUTION: Some Yamaha Digital Musical Instrument products have modules that plug into the unit to perform various functions. The contents of a plug-in module can be altered/damaged by static electricity discharges. Static electricity build-ups are more likely to occur during cold winter months (or in areas with very dry climates) when the natural humidity is low. To avoid possible damage to the plug-in module, touch any metal object (a metal desk lamp, a door knob, etc.) before handling the module. If static electricity is a problem in your area, you may want to have your carpet treated with a substance that reduces static electricity build-up. See your local carpet retailer for professional advice that relates to your specific situation.

Model _____

Serial No. _____

Purchase Date _____

This information on safety is provided to comply with U.S.A. laws, but should be observed by users in all countries.

ABOUT THIS MANUAL

Most owner's manuals tell you how to use the product. We will explain how to operate the MEP4, and give some of examples of how it can be used. But there is no wrong way to use the MEP4. It is totally up to your creativity to use this amazingly flexible tool to the fullest extent. The separately included "MEP4 Example Book" will give further detailed setups that you will want to try out.

CONTENTS

ABOUT THIS MANUAL	1	UTILITY MODE (Various useful functions)	35
INTRODUCTION	2	MEMORY PROTECT	35
PRECAUTIONS	3	MEMORY NAME INPUT	35
FRONT/REAR PANEL	4	EDIT BUFFER INITIALIZATION	36
HOW DOES THE MEP4 WORK?	6	PROGRAM CHANGE RECEIVE	37
OPERATION (RUN mode)	9	FOOT SWITCH ASSIGN	40
SHORT OUTLINE OF EDIT MODE	11	MIDI MONITOR	41
SIMPLE SETUP EXAMPLE		MIDI BULK DUMP	42
(Echo Effect)	12	EXAMPLE SETUP A	
STORE	18	(MEP4 + DX7 + TX7)	44
A CLOSER LOOK AT EDIT MODE	20	EXAMPLE SETUP B (MEP4 + KX88 +	
DATA PRESETTER	21	TX816 + RX11)	50
CHANNEL FILTER	23	IDEAS AND SUGGESTIONS	56
MESSAGE FILTER	24	SPECIFICATIONS	58
DATA MODIFIER	26	ADDITIONAL INFORMATION	59
DELAY PROCESSOR	33	CHARACTER TABLE	60
OUTPUT ASSIGNER	33	WHAT'S HEXADECIMAL?	61
ALL NOTE OFF	34	BINARY, DECIMAL AND	
		HEXADECIMAL CONVERSION	63
		WHAT'S MIDI?	64
		MIDI FORMAT TABLE	66
		SYSTEM EXCLUSIVE DATA FORMAT ..	69
		MEP4 PROCESS PARAMETER CHART	70
		MIDI IMPLEMENTATION CHART	

INTRODUCTION

Thank you for purchasing the MEP4 MIDI Event Processor. The MEP4 is a totally new type of device that gives you complete control over MIDI signals. You can use it to change, ignore, filter and delay any type or types of MIDI signals.

"What can I do with the MEP4?" The answer is "just about anything," but here are a few examples.

Double-tracking: By setting the MEP4 to send a slightly delayed duplicate Note On signal for each one it receives, you can get the sound of two instruments played in unison. You can also set the delayed note to be sent on a different MIDI channel, which will give you two different instruments in unison.

Echo: You can delay the MEP4 output, which will give you an echo effect. You can set the MEP4 to send out a note (or notes) a set interval higher or lower than the note it receives, producing an echo of a different note!

Keyboard split: Using the MEP4, you can split any MIDI keyboard into up to 4 sections (overlapping sections if you wish), and send Note On messages on a different MIDI channel from each section.

Turn your MIDI keyboard into a MIDI master controller: You can set the MEP4 to change incoming Modulation Wheel messages into outgoing Portamento Time messages. Or change Data Entry +1/-1 messages into Mono On/Poly On messages.

Increase or decrease Aftertouch or Velocity Sensitivity: Do you play with a heavy hand? Set the MEP4 to cut in half (or a quarter or an eighth) all Aftertouch or Velocity information. Or do the same with the Pitch Bend Wheel or Breath Controller

Accent notes with another sound: Set the MEP4 to send an additional Note On message to a different tone generator whenever you play a note especially strongly.

The uses mentioned above show just a small fraction of the MEP4's possibilities. The MEP4 will multiply the flexibility and power of any MIDI keyboard setup.

STOPI When we refer to MIDI bytes in this manual, we will always use Hexadecimal numbers. If you do not know what these are, go and read p.61 "What's Hexadecimal?"

STOPI If you are a little unsure about your knowledge of MIDI, go and read p.64 "What's MIDI?"

PRECAUTIONS

LOCATION

Avoid placing the MEP4 in direct sunlight or close to a source of heat. Also, avoid locations in which the device is likely to be subjected to vibration, excessive dust, cold or moisture.

HANDLING

Avoid applying excessive force to the switches, dropping or rough handling. While the internal circuitry is of reliable integrated circuit design, the MEP4 should be treated with care.

POWER CORD

Always grip the plug directly when removing it from an AC receptacle. Removing the plug from the AC receptacle by pulling the cord can result in damage to the cord, and possibly a short circuit. It is also a good idea to disconnect the MEP4 from the AC receptacle if you don't plan to use it for an extended period of time.

CLEANING

Use only a mild detergent on a cloth, and dry with a soft cloth. Never use solvents (such as benzine or thinner) since they can melt or discolor the finish.

ELECTRICAL STORMS (LIGHTNING)

Computer circuitry, including that in the MEP4, is sensitive to voltage spikes. For this reason, the MEP4 should be turned off and unplugged from the AC receptacle in the event of an electrical storm. This precaution will avoid the chance that a high voltage spike caused by lightning will damage the device.

ELECTROMAGNETIC FIELDS

Computer circuitry is also sensitive to electromagnetic radiation. Television set, as well as radio receivers, transmitters and transceivers, and wireless microphone or intercom system are all potential sources of such radiation, and should be kept as far away as possible.

FRONT/REAR PANEL

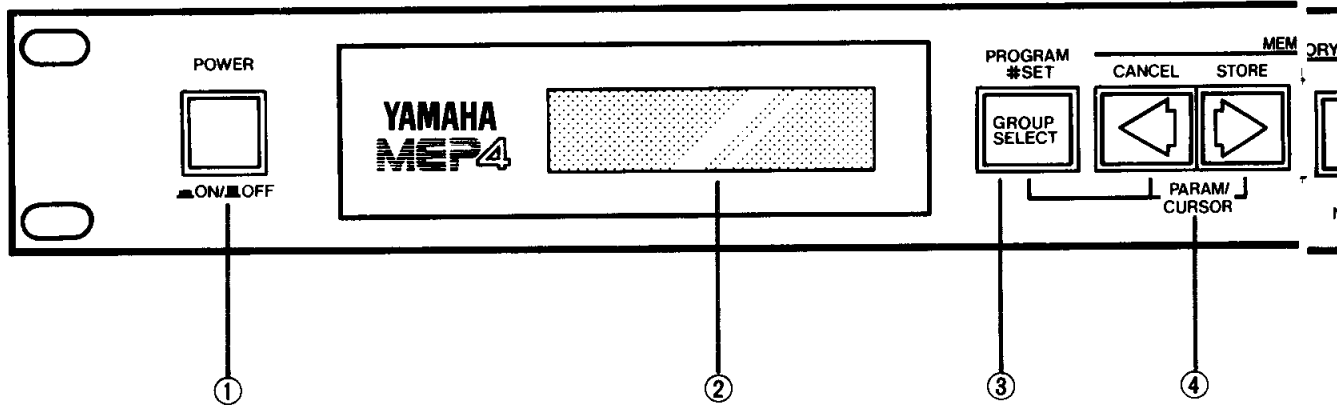

① POWER SWITCH

The LCD indicates power on, so there is no separate power indicator.

② LCD

16-character Liquid Crystal Display, backlit for high visibility. In RUN mode this shows the memory and name. In EDIT and UTILITY modes it shows the parameter or operation.

③ GROUP SELECT

In RUN mode use this together with the cursor switches to select memories by program number. In EDIT and UTILITY modes use it with the cursor switches to select parameter groups.

④ CURSOR

In RUN mode this operates the Store function, and in EDIT and UTILITY modes it selects parameters.

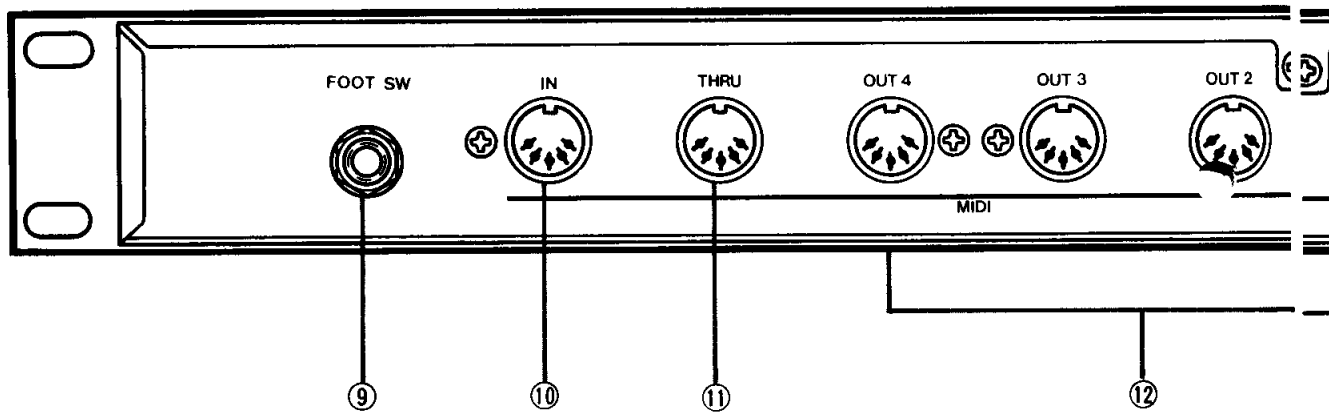

⑨ FOOT SWITCH JACK

An optional foot switch such as the FC-4 or FC-5 can be used to select MEP4 memories, programs, or program change mode.

⑩ MIDI IN

MIDI messages coming in to this terminal can be processed by the MEP4.

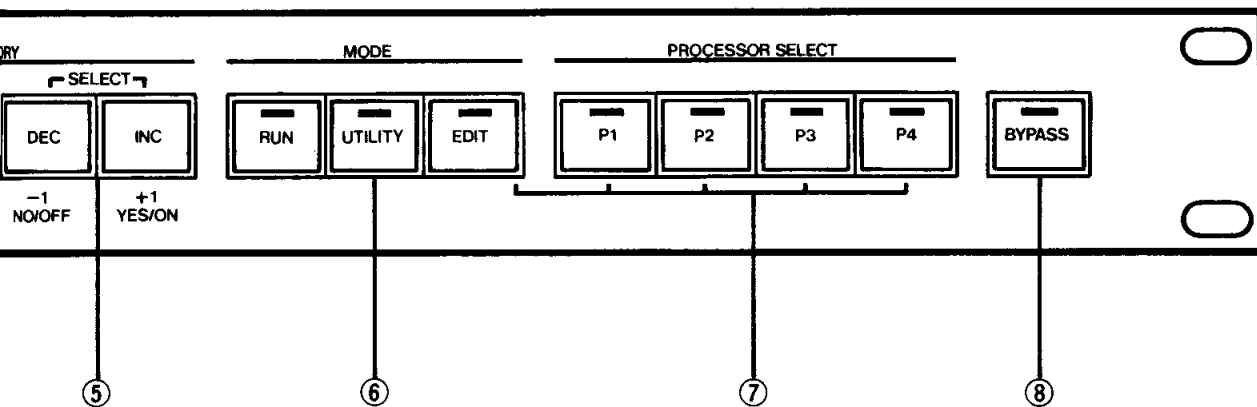

⑤ **DEC/INC**
 In RUN mode use these to select memories. In EDIT and UTILITY use these to change parameter settings.

⑥ **MODE**
 Switch between the three operation modes. LEDs indicate the current mode of operation. In RUN mode the RUN LED will flash to indicate a modified memory.

⑦ **PROCESSOR SELECT**
 In all modes, these turn each processor on or off. In EDIT mode, you can switch to editing another pro-

cessor by pressing a Processor Select switch while holding down "EDIT". LEDs indicate which processors are on. In EDIT mode, a flashing Processor Select LED indicates which processor is being edited.

⑧ **BYPASS**
 Bypasses the MEP4, stopping all operation and in effect turning it into a MIDI THRU box. No other switches will function when the MPE4 is bypassed. The LED indicates that the MEP4 is bypassed.

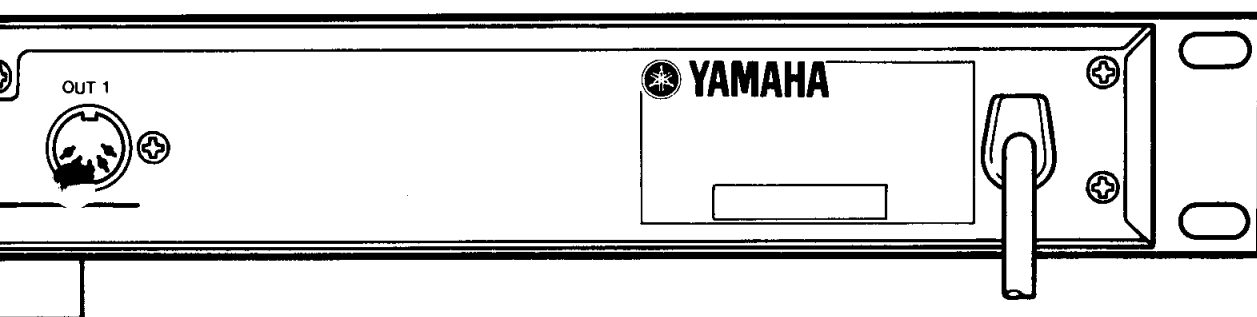

⑪ **MIDI THRU**
 All MIDI messages received at MIDI IN are sent unchanged from this terminal.

⑫ **MIDI OUT 1-4**
 The output of each processor can be assigned to any MIDI OUT 1-4 (Outports 1-4).

HOW DOES THE MEP4 WORK?

Before you attempt to use the MEP4, let us give a general explanation of how it works. As we mentioned already, the MEP4 is a device for filtering, modifying and delaying MIDI messages.

4 Processors

The MEP4 has 4 independent processors. Each processor can be set to accept one or more different types of MIDI message, modify the status or data byte(s) of a selected type of message, delay it for up to 3 seconds, and send it out of any one of all 4 output ports (MIDI OUT 1-4 jacks).

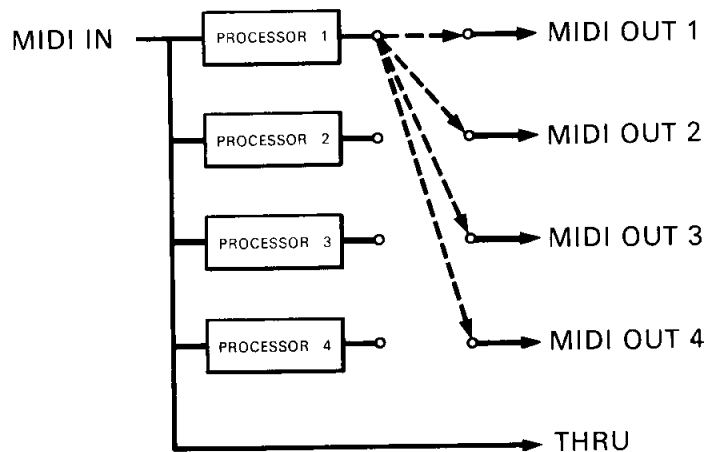

Each Processor looks like this inside.

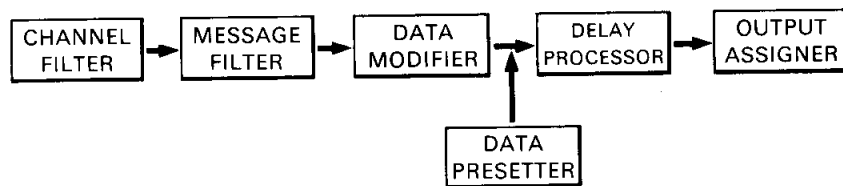

Let's follow how a MIDI message goes through a processor.

Channel Filter

A MIDI message has been received. First the Channel Filter checks to see whether or not it has an acceptable MIDI channel number. The Channel Filter can be set to accept any one, several, or all MIDI channels. If the incoming MIDI message does not have an acceptable channel number, it is rejected and goes no further. For example, if a Note On message for middle C with channel number 1 is received.

90. 3C. 5D

The Channel Filter checks the channel number.

Message Filter

Next the MIDI message must pass the Message Filter. Here it is checked to see if it is an acceptable type (status) of message. The Message Filter can be set to accept or reject each status independently. For instance, you can set it to accept Note On messages and reject Program Change messages.

90. 3C. 5D

The Message Filter checks the status.

Data Modifier

This lets you modify MIDI messages that have made it this far. Here you choose which type of message will be modified and how it will be modified. For instance, you can set it to modify all Note On messages by adding 12 to the first data byte. This would have the effect of sending out a MIDI Note On message an octave higher than the one that was received. (The rest of the messages that got past the Channel Filter and message filter are passed on unchanged to the Delay Processor.)

90. 3C. 5D

The Data Modifier can change any part(s) of the message.

Delay Processor

Here you can specify a time delay from 0 to 3 seconds (in 1 msec steps). All MIDI messages that make it past the Channel Filter and Message Filter are sent out after this delay time.

The Delay Processor delays all outgoing MIDI messages except System Exclusive messages.

Output Assigner

The MEP4 has four output ports (MIDI OUT 1-4). The output of each processor can be sent out of any one of these output ports. You can assign the output of all four processors to be sent out of one port, or assign each processor to have its own output port. Also, this is where you can specify the channel of all outgoing MIDI messages. You may leave the channel numbers just the way they came in, move all channel numbers up or down by a certain value, or send out all the MIDI messages from that processor on one channel no matter what the original channel was.

90. 3C. 5D

The Output Assigner can determine the channel number.

This way, you can use the MEP4 to filter, modify and delay any type of MIDI message.

Data Presetter

In addition to the above functions, there is a "one time" function called the Data Presetter. Using this, you can automatically send certain messages each time a MEP4 memory is selected. For instance, you can automatically set a tone generator to voice number 25, the volume to full and the modulation wheel to zero every time you select a certain MEP4 memory. This function is very useful in initializing your setup at the beginning of a song.

The Data Presetter lets you send one Program Change, one Pitch Bender position, and two control change messages of your choice from each processor. (Control Changes include Volume, Modulation Wheel, Poly/Mono, Portamento Time, Sustain On/Off, etc.)

OPERATION (RUN mode)

In RUN mode you can select and store memories, and turn each processor on and off. To become familiar with the MEP4, connect the AC power and turn it on. For now, don't bother connecting any MIDI cables. When you turn the power on, the MEP4 will be in RUN mode. You will normally use the MEP4 in this mode. The LCD will be displaying a memory number and a 9 character memory name (whatever was last selected before the power was turned off).

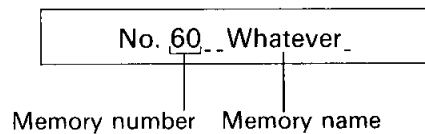

Selecting Memories

In RUN mode, press **DEC** or **INC** to select MEP4 memories. Holding down either one will move you quickly up or down.

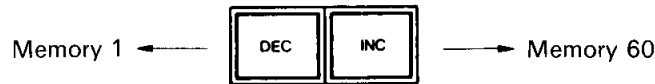

There are other ways of selecting MEP4 memories from a MIDI keyboard or using the footswitch (p.37 and p.40), but don't worry about them now. The MEP4 stores one complete setup (the settings of all 4 processors) in one memory. You can make your own setting, give it a name, and store it. The MEP4 has 60 memories. Each memory also remembers whether each processor is on or off, and as you cycle through the memories you will notice that the Processor LEDs turn on or off depending on the setup in that memory.

Processor Select

While in RUN mode, you can turn the output of each processor on or off by pressing its Processor Select switch.

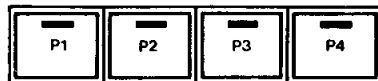

Bypass

No matter what mode you are in, pressing **[BYPASS]** will completely defeat the MEP4. (ie. it will behave just like an ordinary MIDI THRU box.) All input signals will be sent unchanged to all four output ports (MIDI OUT 1-4). WHEN THE BYPASS SWITCH IS ON, NO OTHER SWITCHES WILL OPERATE. Press **[BYPASS]** again to return to normal operation. (When **[BYPASS]** is pressed to return to normal operation, the Data Presetter for each module will send out its specified messages. See p.21)

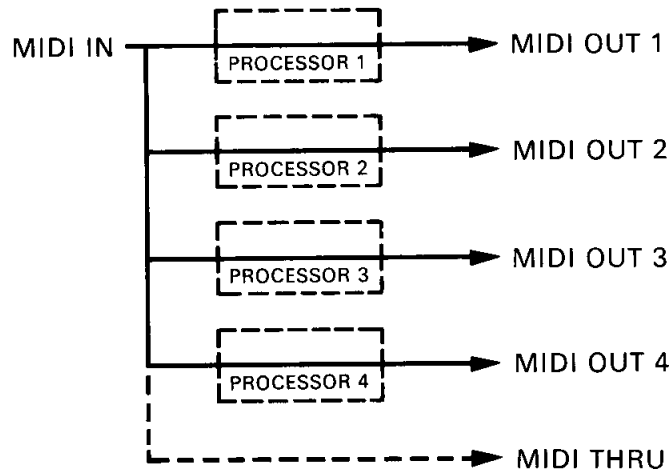

Other RUN Mode Functions

In RUN mode you can also store your own settings in memory (p.18) and select MEP4 memories by the MIDI Program Change numbers they are linked to (p.39), but we will explain these functions later.

Store	See p.18
MIDI Program Change	See p.39

SHORT OUTLINE OF EDIT MODE

EDIT mode is where you decide how the MEP4 will modify incoming MIDI messages. To enter EDIT mode, press **[EDIT]**. You edit one processor at a time, and the Processor Select LED will blink to let you know which one you are now editing.

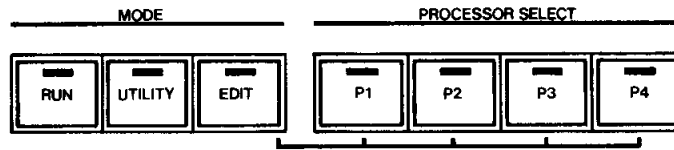

Changing Processors in EDIT Mode

Any time you are in EDIT mode, you can switch to editing another processor. Hold down **[EDIT]** and press the switch of the processor you want to edit. The LED of the newly select processor will begin blinking.



Using this, you can quickly compare the settings of a certain parameter for the 4 Processors.

EDIT GROUPS

As we explained on p.6-8, there are 6 "blocks" or groups of functions which you can set in EDIT mode. Hold down **[GROUP SELECT]** and use **[LEFT]** **[RIGHT]** to move through the groups. As long as you are pressing **[GROUP SELECT]**, the LCD display will show the group names.

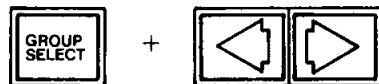

- ① Specify an initialization message to be sent whenever that MEP4 program is selected.
- ② Specify which channels are to be accepted.
- ③ Specify which messages are to be accepted.
- ④ Change the Status Byte or Data Byte of selected MIDI messages.
- ⑤ Delay the output of the module from 0-3,000 milliseconds.
- ⑥ Specify the MIDI channel of the outgoing messages and send the output to MIDI OUT 1-4.

SIMPLE SETUP EXAMPLE (Echo Effect)

In order to give you an idea of how to operate the MEP4, we will set it up to send out a delayed Note On message and Remember that this is just a simple example to familiarize you with the MEP4. There may be some LCD displays we have not explained, but we will cover all EDIT mode functions in detail starting on p.20.

Connections

Depending on the MIDI equipment you have, connect the MEP4 in one of the setups shown below. Any MIDI keyboard and tone generator may be used.

DX7 + MEP4

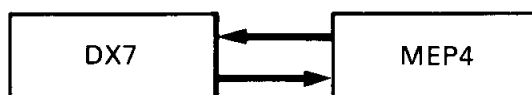

DX7 + MEP4 + TX7

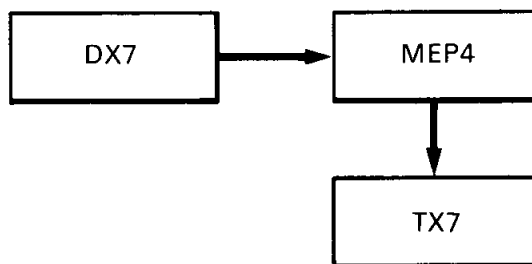

(In example setup A and B on p.44 and p.50 we will discuss some more complicated setups.)

The Edit Buffer

Whenever you select an MEP4 memory, data is copied into a temporary space called the Edit Buffer, and this data tells the Processors how to behave. All changes we make in the settings affect this Edit Buffer, and will NOT change the memory. When you select another memory, the newly selected data is copied into the Edit Buffer and any changes you have made are lost. If you want to keep the changes you have made, you must save the Edit Buffer into a memory (any memory 1-60).

Initialize the Edit Buffer

There is a handy function which lets you set all data in the Edit Buffer to a basic setting (described fully on p.36). USE IT WITHOUT FEAR! Any changes you make will not affect the 60 memories unless you Store them there. (See p.18 for how to Store your new settings.) Press **UTILITY**. The Utility Mode LED will light. (It doesn't matter what happens to be displayed in the LCD.) Hold down **GROUP SELECT** and use **◀ ▶** to get the "ED-BUFFER INIT" display



then



+

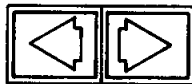

→

ED-BUFFER_INIT_..

Release **GROUP SELECT** and the LCD will change to

Init_ED-BUFFER_?

Now press **INC**. The MEP4 will ask you

_Are_you_Sure?_

so press **INC** again. The LCD will read

_*_Completed!*_

for a second and will then return to the "Init ED-BUFFER?" display.

A Simple Echo Setup

Let's set up the MEP4 to produce an echo effect. We will use only one processor, and set it up to accept all channels (Channel Filter), accept Note On and Off messages (Message Filter), add 12 to the first data byte (note number) of the Note On message so as to move it up an octave (Data Modifier), wait 400 msec before sending the message (Delay Processor), and send it out of MIDI OUT 1 on the same channel as it was received (Output Assigner).

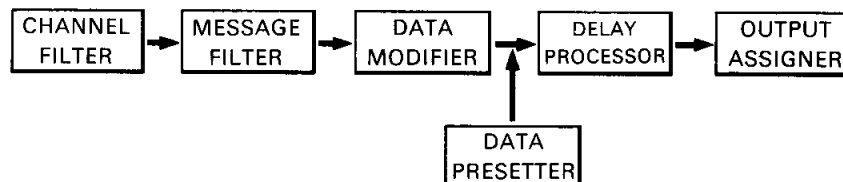

Since the initialized setting is to accept all channels and accept Note On and Off messages, we don't need to change the Channel Filter or Message Filter. We will start by setting the Data Modifier.



Begin Editing

Press **EDIT** and the Processor Select LED #1 will begin to blink, indicating that we are editing Processor 1. The LCD will briefly show a message (we don't know what; it depends on which Edit Group was last selected),

????????????????

and then change to

????????????????

(depending on which Edit Parameter was last selected). Hold down **GROUP SELECT** and use the   keys to get the "DATA MODIFIER" display. (If you lose track of where you are, take a look at the Edit mode chart on p.20)

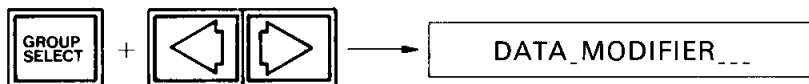

Select What We Will Modify

Release **GROUP SELECT** and the LCD will show

0:MSG:* *

This is where you select the message you want to modify. We want to change Note On messages (see MIDI data format table on p.66), so press **INC** twice to make the LCD read

0:MSG:9n.xx.yy

This indicates that this processor (P1, as indicated by the blinking LED) will be modifying all Note On messages. Press  4 times and the display will show

1:* * *:.....

with the cursor blinking on the "***"

Select How We Will Modify It

This is where we select how we are going to modify the message we selected in the previous step. We want to add 12 to the note number (first data byte) to shift it up an octave. Press **INC** 3 times to make the LCD show.

1:OFS:xx,V= ___0

Here we will Offset (OFS) the first data byte by +12. (The "xx" in the LCD already indicates that the first data byte will be modified, so we don't have to change this.) To select the offset value, press  to move the blinking cursor to "V= □" and press **INC** until it reads "V=+ 12" (positive 12).

1:OFS:xx,V=+_12

We have set the Data Modifier to modify Note On messages by adding 12 to their first byte (note number). ("V=..." is a decimal number.)

Adding Delay

Now we will add a delay to make an Echo effect. Hold down **GROUP SELECT** and press  once to enter the Delay Processor.





When you release **GROUP SELECT** the LCD will show

DELAY_TIME= ___0

Press **INC** Until the LCD shows

DELAY_TIME=_400

(It will go quicker if you use   to move to the 100's column and move up directly by 100.)

Selecting the output channel

Now we set the output channel. Hold down **GROUP SELECT** and press  once to enter the Output Assigner.

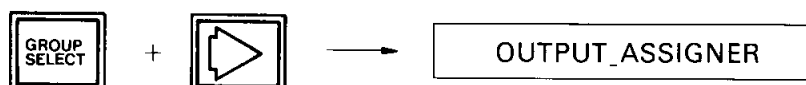

When you release **GROUP SELECT** the LCD will show

OUT-CH_ASSIGN_ = 1

indicating that all outgoing messages will be sent with MIDI channel number 1. Press **DEC** to make the LCD read

OUT-CH_ASSIGN_ = *

When the Out-Ch. Assign is " * ", outgoing messages will be sent out with the same MIDI channel number they had when they came in.

Selecting the Output Port

The MEP4 has 4 MIDI OUT jacks on the rear panel, and the output of each processor can be sent to any one of these. In the initialized setting, processors P1-P4 are assigned to Outports 1-4. Since the receiving MIDI device (TX7 or DX7) is connected to MIDI OUT 1 (in this example), we don't have to change the outputport setting, but you can see for yourself by pressing  twice to display

OUTPORT_ASSIGN = 1

indicating that this processor is sending its output to MIDI OUT 1.

Try It Out

With your equipment connected as shown on p.12, play a note. You will get an echo of the same note an octave higher. If you are using the setup with the TX7, the echo will come from the TX7.

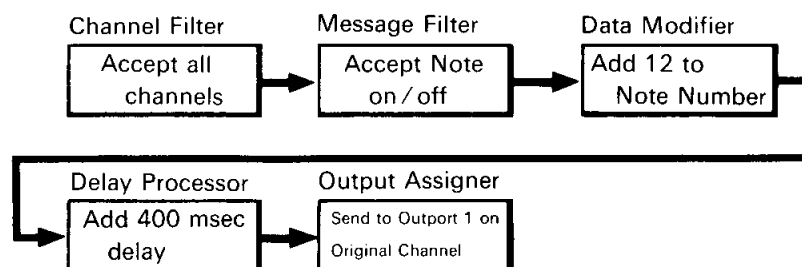

If it doesn't work, check the MIDI reception channel of the receiving device to see that it matches the transmitting channel. If you are using a single DX7 to transmit and receive, the DX7 reception channel must be set to ch.1. (The DX7 transmits only on MIDI channel 1.)

Memory-Name Input

Now you can name your new program. Press **UTILITY**. The last time we used Utility mode was to initialize the Edit Buffer, so the LCD will still read



Init_ED-BUFFER_?

Hold down **GROUP SELECT** and press  to reach



When you release **GROUP SELECT** the LCD will read

No.1_.....

or whatever Program No. was last selected before you initialized the Edit Buffer. (Don't worry. The actual Program No. 1 is still safely in memory.) Now select a name character by character. Use   to move from space to space and use **DEC** **INC** to select a character. (There is a complete character table on p.60.)

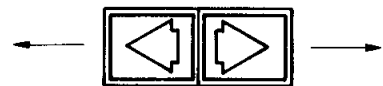

No.1_.....

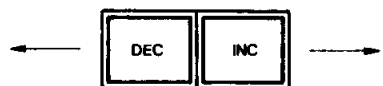

A,B,C,D,E,F,.....u,v,w,x,y,z

Memory Protect

When you have finished entering the new name, you can store the setup you have just made in a memory. But before you can store your newly created setup, you must turn the Memory Protect off. (We are still in Utility mode.) Hold down **GROUP SELECT** and press  once. The LCD will read

MEMORY_PROTECT..

When you release **GROUP SELECT** the LCD will change to

Protect_(ON)_

Turn the Memory Protect off by pressing **DEC**.

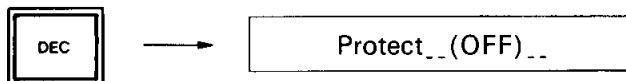

Store

Store is a function in RUN mode, so press **RUN**. BE CAREFUL. IF YOU SELECT ANOTHER MEMORY NOW BY PRESSING **DEC** OR **INC**, THAT DATA WILL BE CALLED INTO THE EDIT BUFFER AND YOUR NEW SETUP WILL BE LOST. Notice that the Run LED is blinking. This warns that the current data has been edited.



Press . The LCD will read

Store_1 to_1_>

or whatever Memory No. was last selected before you initialized the Edit Buffer. BE CAREFUL. The usual roles of the switches are reversed here. Pressing will store the contents of the Edit Buffer (your setup) into the memory number displayed, wiping out the setup that was there before. To change the store destination, use **DEC** **INC**. In this example, let's store our new setup in memory 31. (When the MEP4 is shipped, memories 1-30 contain the setups listed in the separate booklet, and memories 31-60 contain initialized data.)

Press **INC** **DEC** until the LCD reads



Now press to store your program in memory #31. The MEP4 will ask

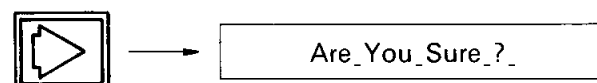

press **INC** to answer "yes." The LCD will show

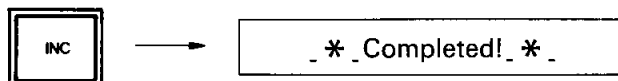

for a second and then return to normal RUN mode. Notice that the RUN LED has stopped blinking, since your edited program has been safely stored in memory. Now you can use **INC** **DEC** to select any other program.

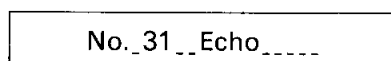

(It would be a good idea to turn Memory Protect back on again when you have finished storing.)

Possible Problems

The setup described above may not be working quite the way you expected. Here are some problems you may already have noticed, and the reasons for them.

- The Sustain Pedal does not affect the echoed note (if you are using a TX7). This is because the Message Filter was set to accept only Note On and Note Off messages. You will have to set it to accept MIDI Control Changes. Page 24 describes the full operation and effect of the Message Filter. (For the same reason, Program Change messages will not be passed on to the TX7. You will have to set the Message Filter to accept Program Changes.)
- When you press a DX7 program select switch, the MEP4 changes to another memory, and behaves in some unexpected way. If this happens, it is because the MEP4 has been set to receive program changes. (See p.37.)

In later chapters we will explain how to create a more useful setup, using all 4 processors. Since this example was meant to introduce you to the MEP4, we kept it simple. By now you should have a fairly good idea of how it works. Now go on and read through the next two chapters "Edit Mode" and "Utility Mode" to learn the full range of functions the MEP4 offers.

A CLOSER LOOK AT EDIT MODE

Changing Processors in Edit Mode

Any time you are in EDIT mode, you can switch to editing another processor. Hold down **EDIT** and press the switch of the processor you want to edit **P1** - **P4**. The LED of the processor you selected will start blinking. This is useful when you want to compare the settings of a certain parameter for each processor.

Turning Each Processor on/off

It is sometimes helpful to work with only one processor active. You can turn off the unneeded processors by pressing **P1** - **P4**. The LED indicates that the processor is active. The processor being edited cannot be turned off.

Looking Inside Each Edit Group

As long as you hold down the GROUP SELECT switch, only the names of the groups will be displayed. But if you release the Group Select switch, you will see that each edit group has several parameters (things you can set or change). Use the **◀** **▶** keys to move back and forth between the parameters inside each group, and use **INC** **DEC** to change the setting of each parameter.

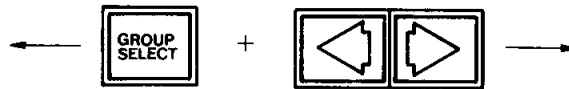

PRGRM(OFF): PITCH(ON):00,40 CNTL1(ON):01,00 CNTL2(ON):07,7F	OMNI ON	NOTE OFF = ON NOTE ON = ON POLY A. TOUCH = OFF CNTL# = ->:**,** PRGRM CHANGE = OFF CH A. TOUCH = OFF PITCH BEND = OFF CH MODE MSG = OFF SYSTEM MSG = OFF	0:MSG:** 1: 2: 3: 4:	DELAY TIME = 0	OUT CH ASSIGN = 1 OUT CH OFFSET = 0 OUTPUT ASSIGN = 1
--	---------	--	----------------------------------	----------------	---

DATA PRESETTER

This is where you can preset 4 messages to be sent whenever that MEP4 memory is selected. You have the option of sending a Program Change message, a Pitch Bender message, and any two Control Change messages. These messages will be sent out on whatever output channel has been specified in the Output Channel Assigner (see p.33). If the Output Channel Assigner has been set to "*", the Data Presetter will do nothing.

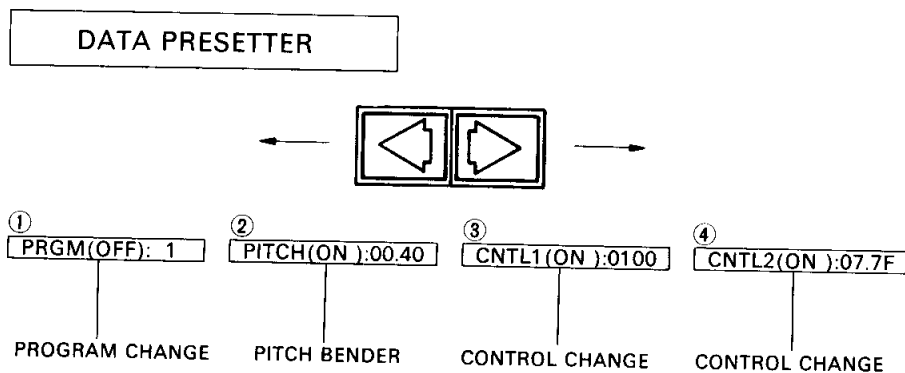

The above is the initialized setting of the Data Presetter. When a MEP4 memory with the above setting is selected,...

- ① PROGRAM CHANGE for the specified program number will NOT be sent.
- ② PITCH BEND with a value of 00.40 (middle position) will be sent.
- ③ CONTROL CHANGE 01 (Modulation wheel) with a value of 0 (lowest position) will be sent.
- ④ CONTROL CHANGE 07 (Volume) with a value of 7F (full) will be sent. (For a complete list of MIDI messages, see p.66)

Editing the Data Presetter

Use to move to the parameter you want to set and use **INC** **DEC** to change setting. The "ON" "OFF" for each message determines whether it will be sent or not.

Examples

- **Program Change:** You can use this to automatically select a different voice number for several different tone generators. For instance, set processors 1-4 to output on MIDI channels 1-4, and set different program numbers in each Data Presetter 1-4.
- **Pitch Bender:** By specifying 00.40 as the data bytes of this message, you can "reset" the pitch bender to normal position. If you had switched MIDI channels with the Pitch Bender still up or down, the tone generator would still think you were "up in the air", and would be out of tune with the rest of the tone generators. Sending a Pitch Bend message with data bytes of 00.40 would tell the tone generator to normalize the pitch.
- **Control Changes 1 and 2:** As with the Pitch Bender, these are useful to bring the tone generator "back to normal." For instance, you could make sure that the tone generator was set to poly mode by setting.

CNTL2(ON_):7F,00

Control Change 7F.00 (Poly On)

When is the Preset Data sent?

The Data Presetter sends its messages whenever

- a. an MEP4 memory is selected
- b. a processor is turned on
- c. the preset data is changed
- d. the delay time is changed
- e. the output channel or output is changed
- f. the Bypass is turned off
- g. there has been an input or output overflow error

Note:

If the Delay Processor (p.33) is set above 0, the Preset data will be sent out after the delay time has elapsed.

CHANNEL FILTER

You can set the Channel Filter to accept all channels (OMNI ON) or any one or more channels (OMNI OFF).

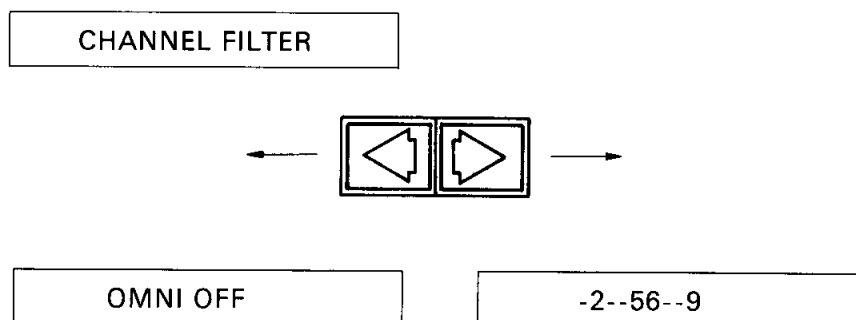

For example, when the Channel Filter is set as above, it will accept MIDI channels 2, 5, 6 and 9. Turn each channel on or off by moving the blinking cursor to the appropriate space and pressing the Off/On switch.

Note:

When the Channel Filter is set to "OMNI ON", it will accept all MIDI channels, and individual channel on/off will have no effect. (You will not be able to reach the individual on/off display.)

MESSAGE FILTER

This is where you select which types of message to accept. You can set it to accept or reject each type of message separately. Move through the choices using and turn each one on or off using **DEC** **INC**.

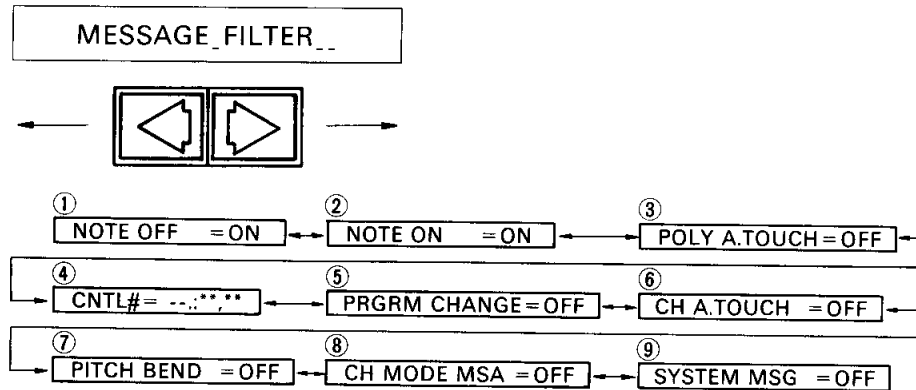

- ① Note Off messages? (8n. xx. yy)
- ② Note On messages? (9n. xx. yy)
- ③ Polyphonic Aftertouch messages? (An. xx. yy)
- ④ Control Changes 00-79? (Bn. xx. yy) (See note on p.25)
- ⑤ Program Changes? (Cn. xx.)
- ⑥ Channel Aftertouch? (Dn. xx)
- ⑦ Pitch Bend messages? (En. xx. yy)
- ⑧ Channel Mode messages? (Bn. 7A-7F. yy)
- ⑨ System messages? (F0-FF)

The setting above is the initialized setting of the Message Filter. Set as shown, only Note Off and Note On messages will be accepted.

Note:

"CNTL#= " is a special case. You can choose to accept all, none, one or two control change messages 00-79. (Control Changes 7A-7F are covered in Mode Messages.)



CNTL# = -->: * *, * *

None accepted

CNTL# = _ALL_.....

All accepted

When the cursor is blinking on the arrow, press **INC** to accept all Control Changes. Move the cursor to the "*" and use **DEC** **INC** to select the control number you want to accept. For instance, if the display reads "*", 01", only Modulation Wheel Control Changes will be accepted. (See p.66 for a table of all MIDI messages.) When both are set to "*", no Control Change messages will be accepted.

Example: Modulation Wheel and Main Volume control changes accepted



CNTL# = -->:07,01

System Exclusive Reception

When the MEP4 receives a System Exclusive message (F0,...) it will send it unchanged out from all processors that have their message filter set to accept system messages. The Delay Processor will not apply to this.

The MEP4 itself will accept two types of System Exclusive message: Memory Bulk data and Memory Bulk Dump Request. These are described on p.69. If the device number of the above two messages does not match that of the MEP4, the message will be passed through unchanged. If the device number matches, the MEP4 will take appropriate action as described on p. 42 ~ 43.

DATA MODIFIER

This is where the real action takes place. The Data Modifier has 5 steps, 0-4. In step 0 you decide what kind of message you want to modify. You can modify any one type of message in a total of 4 ways (steps 1-4). Pressing the   switches will take you through steps 0-4.

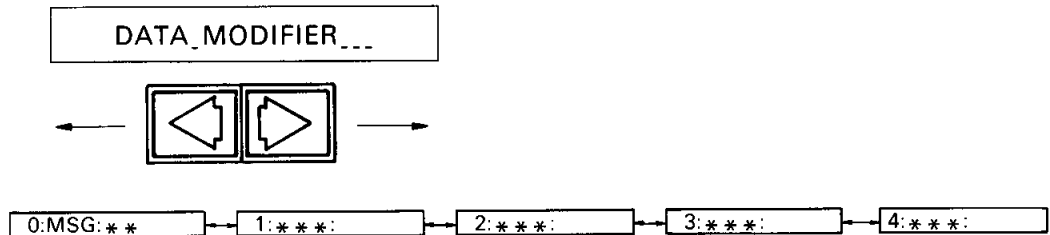

Select The Message to be Modified

When the LCD display is showing "0: MSG:" you can use the **DEC** / **INC** switches to select the message you want to modify. When the display shows "0: MSG:**", no messages will be modified, and all messages that have come this far will be sent unchanged to the next step, the Delay Processor.

Each processor will modify only one type of message at a time. If you want to modify Note On messages in a certain way, and modify Channel Aftertouch messages in another, you will need to use two separate processors. (The MEP4 has four processors, which should be enough for most purposes.)

Choose one type of message to modify

0:MSG:**	No messages	will be modified
0:MSG:8n.xx.yy..	Note Off	"
0:MSG:9n.xx.yy..	Note On	"
0:MSG:An.xx.yy..	Polyphonic Aftertouch	"
0:MSG:Bn.xx.yy..	Control Change	"
0:MSG:Cn.xx.....	Program Change	"
0:MSG:Dn.xx.....	Channel Aftertouch	"
0:MSG:En.xx.yy..	Pitch Bender	"

(You cannot modify System messages (F0-FF) using the MEP4.)

Specify Messages of only Certain Data Bytes

When the display shows xx (and/or yy) for the data bytes, it means that the selected message will be modified no matter what the first (and/or second) data byte is. By moving the cursor to the xx and yy, and pressing **INC** / **DEC** to select a number, you can "narrow the selection." Messages will be modified only if they have the first (and/or second) data byte you specified. (Channel number "n" cannot be changed. Use the channel filter to screen out unwanted Channels.)

Example 1. 0:MSG:9n.xx.00

Note On messages with a second data byte (velocity) of 0 will be modified.

Example 2. 0:MSG:9n.3C.00

Note On messages with a first data byte (note number) of 3C and a second data byte of 00 will be modified.

Example 3. 0:MSG:9n.xx.yy

All Note On messages will be modified no matter what the data bytes are.

6 Possible Modifications

At each step (1-4) you can choose any one of 6 ways to modify the data (or choose not to modify it at all). Pressing the **◀** **▶** switch will take you through the 7 choices. Where you have a choice between modifying the first or second data bytes (xx or yy), select by moving the cursor to xx and pressing either **DEC** or **INC**.

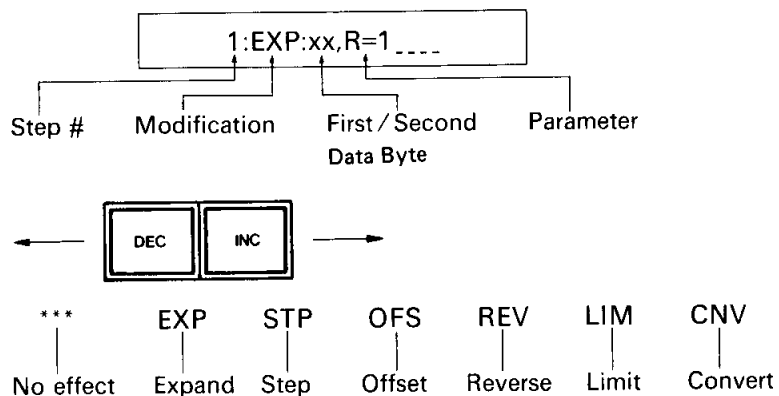

NO EFFECT

.:***:..... No effect

EXPAND

:EXP:xx,R=1

You can multiply the first (xx) or second (yy) data byte of the message by R=1/16, 1/8, 1/4, 1/2, 1, 2, 4, 8, 16. Select whether to modify the first or second data byte by moving the cursor to the "xx" and pressing **DEC** or **INC**. If the resulting data is over 7F, it will be sent as 7F, and if less than 00, it will be sent as 00.

Example 1. If (modify Channel Aftertouch)

(multiply the first data byte by 2)

and a message of D2.20 comes in, D2.40 will be sent out.

Example 2. If (modify Note On)

(multiply the second data byte by 1/2)

and a message of 93.43.60 comes in, 93. 43. 30 will be sent out.

Example 3. If (modify Note On messages which have a velocity of 40)

the "EXP" will be ignored, because "yy" does not appear in "0:MSG:"

STEP

:STP:xx,S=1

Only messages with a data byte (first data byte if xx, second if yy) that is a multiple of the Step will be allowed through. You can select a step between 1 and 16 (decimal). If the step S=1, messages will be allowed through no matter what the data byte is. If the step S=2, only messages with even data bytes will be allowed through.

Example If (modify Channel Aftertouch)

(Step=2)

and a message of D1.31 comes in, nothing will be sent out. If a message of D1.30 comes in, it will be sent on unchanged.

OFFSET

You can add a fixed value (-127 to +127) to the first (xx) or second (yy) data byte. This offset value (V=value) is displayed in DECIMAL numbers. If the resulting data is over 7F, it will be sent as 7F. If less than 00, it will be sent as 00.

Example 1. If (modify Note On)

(add 12 to the first data byte)

and 93.30.5D comes in, 93.3C.5D will be sent out.

(This would have the effect of sending out a Note On one octave higher than the incoming note.)

Example 2. If (modify Modulation Wheel)

(subtract 16 from the Modulation Wheel data)

and B5. 01. 09 comes in, B5. 01. 00 will be sent out, since the resulting data was less than 00.

REVERSE

:REV:xx, FIX = 40

You can reverse the data around a selected Fixed middle point. Actually since 00-7F is an even number (80 hex. or 128 decimal), there is no middle point. Instead, the Fix point and Fix point-1 switch places.

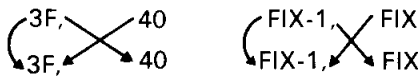
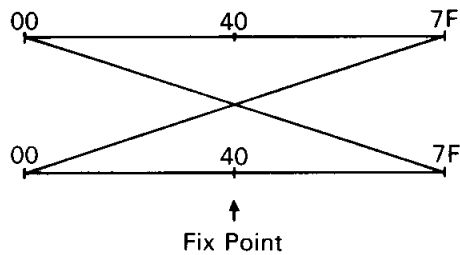

Example If (modify Note On)

(reverse the Key number around the center)

and 92. 05. 6A comes in, 92. 7A. 6A will be sent out.

This would have the effect of reversing the keyboard around E3.

LIMIT

_:LIM:xx, 00 ≤ D ≤ 7F

Only messages with data falling within the limit will be allowed through. (It is impossible to set the lower limit higher than the upper limit.)

Example If (modify Note On)

(limit)

only notes between middle C and an octave above middle C would get through.

This is the basis for the many amazing keyboard splits you can do with the MEP4.

CONVERT

:CNV:→8n.xx.yy

This is different from the other 5 data modifications. It lets you change the Status as well as data of the message being modified. You can select statuses 8n-En, and specify the first and/or second data byte to be a constant number (00-7F) or either the first (xx) or second (yy) data byte of the incoming message. Use **DEC** **INC** to select xx, yy, 00,...7F.

Example 1. If (Note On, velocity 0)

(Note Off, velocity 40)

all incoming Note On messages with a velocity of 0 would be Converted into Note Off messages with a velocity of 40. (Notice that the first data byte xx would remain unchanged.)

Example 2. If (Control Change 'Modulation Wheel')

(Channel Aftertouch)

the second data byte of the Modulation Wheel Control Change message would be sent out as the data byte of a Channel Aftertouch message.

Note:

All modifications coming after a Convert will be ignored, so it is best to place Convert last (in the 4th step). This also means that you cannot have two Converts in one processor (not that there is any reason for wanting to do this).

Example If (Channel Aftertouch)

(cut the Channel Aftertouch data by a half)

2:CNV:_ → Bn.07.xx

(convert Control Change 'Volume' messages with the original Channel Pressure data as the new Volume data)

3:OFS:xx,V=+_30

(add 30 to the Control Change 'Volume' data)

The Offset in step 3 will have no effect because of the Convert in step 2.

Sequence of Modification

The Data Modifier of each processor has 4 steps in which data can be modified. These modification are carried out sequentially (one after the other). Changing the order may sometimes change the end result.

Moving a modification

For example, after you have already set modifications for steps 1, 2 and 4, you decide to insert another modification in step 1. There is no need to redo all your work. With the cursor on step number 1, press **INC**.

Data A

0:MSG:9n.xx.yy
□:LIM:xx,00 ≤ D ≤ 3C
2:OFS:xx,V= + 12
3:***:
4:CNV: → Bn.01.xx

Data B

0:MSG:9n.xx.yy
1:***:
□:LIM:xx,00 ≤ D ≤ 3C
3:OFS:xx,V= + 12
4:CNV: → Bn.01.xx

The settings of steps 1 and 2 will roll forward, leaving you room to insert another modification in step 1. Now the Data Modifier will look like Data B, and the cursor will be on step number 2. This lets you insert a modification in step 1. Notice that this was possible only because step 3 was empty. If you press **INC** again while in the condition of Data B, the LCD will warn you

Modifier_Full_!

for about one second.

You can also do the reverse. Suppose in the condition of diagram B. you wanted to insert a step between 3 and 4. Move the cursor to step number 3 and press **DEC**. The Data Modifier will return to the condition of Data A. If there had not been an empty space in step 1, the LCD would have warned you

Modifier_Exist_!

for about one second.

DELAY PROCESSOR

This is where you can delay the entire output of the processor. All messages that have gotten this far (not only the modified ones) will be delayed. Select the delay time from 0-3000 msec by pressing the **DEC** / **INC**. (You can quickly set long delay times by moving the cursor to the 1000's or 100's place.) System Exclusive messages will not be delayed.

DELAY_TIME_ = __0

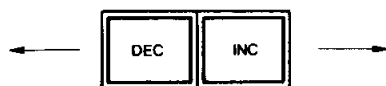

0 msec

3000 msec

If the Data Presetter is used (see p.21), messages from it will be delayed in the same way.

OUTPUT ASSIGNER

This is where you set the MIDI channel of the processor output, and send it to one of the 4 Outports (MIDI OUT 1-4).

Output Channel Assign

OUT_CH_ASSIGN = 1

Use the **INC** / **DEC** to select the MIDI channel for all output; *, 1, 2,...16. If you select "*", messages will be sent out with the same channel number they originally had. (If "*", the Data Presetter will not function.) If you select a number, all outgoing messages will be sent with that channel number.

Output Channel Offset

OUT_CH_OFFSET = __0

The channel number of all outgoing messages will be moved up or down depending on the Offset. (An Offset of 0 has no effect.) For instance, if an incoming message has channel number 2 and the offset is 4, the message will be sent out with a channel number of 6.

91.3C.40 → Offset 4 → 95.3C.40

Outport Assign

OUTPORT_ASSIGN=1

The output of each processor can be sent to any one of Outports 1-4 (MIDI OUT 1-4). You can send the output of each processor to a different outport, or all to the same outport.

Caution:

Though not likely, it is possible to make the MIDI output overflow by assigning all processor outputs to one outport and sending very frequent messages (eg. a continuous controller such as Pitch Bend or Modulation Wheel). After all, if the MEP4 is sending out 4 messages for every 1 that it receives, the output will not be able to keep up. MIDI is allowed to send only (!) 3000 bytes (about 1000 average messages) in one second. If there is an input or output overflow, Note Off messages for all notes currently on will be sent (see below), and the MEP4 will display

RX_buffer_full_!

(receive buffer full)

TX_buffer_full_!

(transmit buffer full)

depending on what the problem is. Pressing a Mode switch will return you to normal operation.

ALL NOTE OFF

When one of the following events occurs, the MEP4 will send Sustain Off (Bn. 40.00) and Note Off (8n.xx.40) messages for all notes that are currently on.

- a. a memory change
- b. a processor is turned off
- c. a parameter (aside from the Data Presetter) has been modified
- d. Edit Buffer has been initialized
- e. Bypass is turned on
- f. input or output buffer has overflowed

UTILITY MODE (Various useful functions)

There are 7 functions in UTILITY mode.

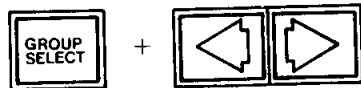

Protect (OFF) Protect (ON)	No: xx—	Init ED BUFFER	RCV (No.), Ch(1) RCV-Mode (PRG #) 128&as.60 Abcdefghi Init ASSIGN # ?	Func(MEMORY-INC) Func(PGRM-INC) Func(RCV. MD-SEL)	(P1)p= 1: 90.3C.40 Cut F8/FE (No)	DEVICE # =1 MEM Bulk Dump
-------------------------------	---------	----------------	--	---	--------------------------------------	------------------------------

MEMORY PROTECT

When Memory Protect is on, you will not be able to store programs. Even if MIDI Bulk Data of MEP4 memory is received, it will be ignored, and the existing memory will be preserved. (See bulk data, p.42) For safety's sake, leave Memory Protect on except when you want to store a program you have just edited. Use **DEC** **INC** to turn Memory Protect on and off.

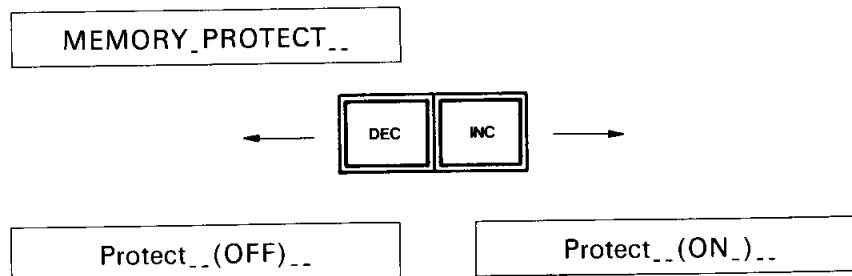

MEMORY NAME INPUT

This is how you name programs you have edited.

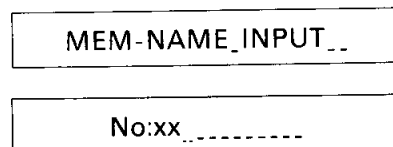

There are 9 spaces for the program name. Use to move the cursor to the space you want to change and use **DEC** **INC** to run through the characters. Characters are in alphabetical order, capital and lower case. There is a complete character table on p.60.

**EDIT BUFFER
INITIALIZATION**

ED-BUFFER_INIT_..

Use this when you want to create a setup from scratch. It will set the Edit Buffer to the initial values shown below. (This will not affect anything in the memory, so don't worry. Memory is affected only when you Store. See p.18)

Init_ED-BUFFER_?

Now press **INC**. (If you press **DEC** nothing will happen. If you don't want to initialize, use the **GROUP SELECT** + **◀ ▶** switches to move to another function.) The MEP4 will ask you

_Are_You_Sure?_

so if you are, press **INC**. (Pressing **DEC** will take you back to the previous display.) The LCD will read

_*_Completed!*_

for a second and will then return to the "Init ED-BUFFER?" display.

DATA PRESETTER		
PROGRAM (ON/OFF)	1	
PITCH (ON/OFF)	00	40
CONTROL 1 (ON/OFF)	01	00
CONTROL 2 (ON/OFF)	07	7F
CHANNEL FILTER		
OMNI : (ON/OFF)		
1	2	3
4	5	6
7	8	
9	10	11
12	13	14
15	16	
MESSAGE FILTER		
NOTE OFF	(ON/OFF)	
NOTE ON	(ON/OFF)	
POLY A. TOUCH	ON/OFF	
CONTROL NO.	ALL/**	
PROGRAM CHANGE	ON/OFF	
CH A. TOUCH	ON/OFF	
PITCH BEND	ON/OFF	
CH MODE MES.	ON/OFF	
SYSTEM MES.	ON/OFF	

DATA MODIFIER	
0	MSG : **
1	*** :
2	*** :
3	*** :
4	*** :
DELAY PROCESSOR	
DELAY TIME	0
OUTPUT ASSIGNER	
OUT-CH ASSIGN	1
OUT-CH OFFSET	0
OUTPORT ASSIGN	

All four processors will contain the same data. However the outport assign will be the same as the processor number. (Eg. processor 3 will be initialized to outport=3.)

PROGRAM CHANGE RECEIVE

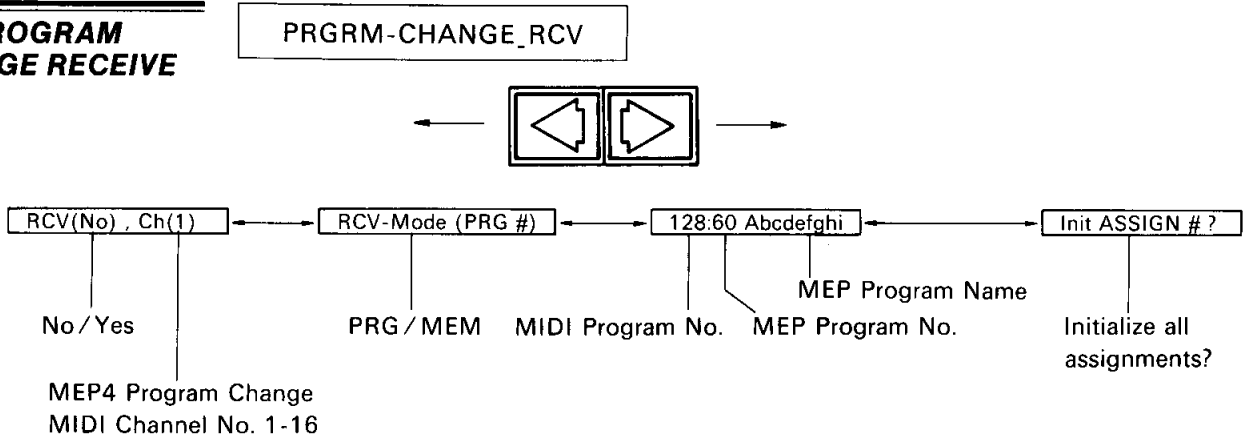

On p.9, we learned how to select MEP4 memories using the **DEC** / **INC** switches while in RUN mode. There are two other ways to select MEP4 memories. One of them is to set the MEP4 to respond to incoming MIDI Program Change messages. (The other way is with a footswitch. See p.40) This lets you select MEP4 memories at the touch of a program change switch on a MIDI keyboard, instead of holding the **DEC** / **INC** switch down and waiting for the right number.

Enable Program Change

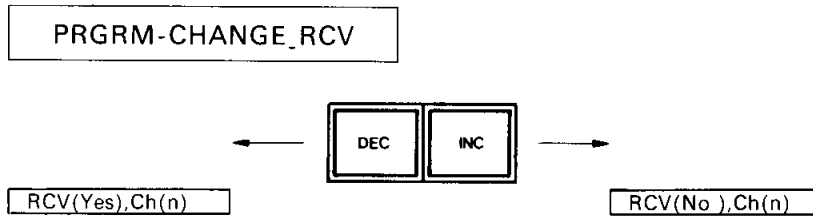

Select MEP4 Program Change Reception Channel

When set to "RCV (YES)", the MEP4 will change its own program when it receives a MIDI Program Change message on channel "n". Select the channel number by moving the cursor to "Ch(n)" and using the **DEC** / **INC** switches to choose MIDI channel 1-16.

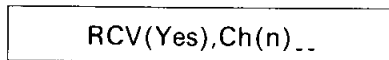

Select channel "n" = 1-16 by pressing **DEC** **INC**

Program Change Receive Mode

There are two ways the MEP4 can respond to incoming MIDI Program changes

*By Memory #
(Direct select)*

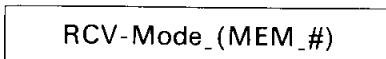

When the MEP4 is set to "RCV-Mode (MEM #)" and "RCV(Yes)", it will switch memories to match incoming MIDI Program Change messages on the channel "Ch(n)." For example if the MEP4 has been set to

RCV(Yes),Ch(9)_

RCV-Mode_(MEM.#)

and receives a MIDI message "C8.05" (Program Change on channel 9, program number 6), it will switch to memory #6. MIDI Program Changes can be 1-128, but the MEP4 has only 60 memories. So, when the incoming program number was 65, MEP4 memory #5 would be selected.

**By Program #
(Indirect select)**

RCV-Mode_(PRG.#)

There is a Program Change table in memory that holds a MEP4 memory number for each MIDI Program Change 1-128. This lets you assign any MEP4 memory to each incoming MIDI Program Change. For example you can have the MEP4 switch to MEP4 memory #15 whenever it receives a MIDI Program Change #32. Using **DEC** **INC** select the MIDI Program Change number to respond to.

128:60_Abcdefghi

Select MIDI Program Change 1-128

Move the cursor to the MEP4 memory number and select the memory that you want to assign to that MIDI Program Change.

128:60_Abcdefghi



Select MEP Memory 1-60

In the example below, when the MEP4 receives a MIDI Program Change #1, it will switch to MEP4 memory #15. When it receives MIDI Program Change #2, it will switch to MEP4 memory #60.

A sample program change table

Incoming MIDI Program Number	:	MEP4 Memory Number & Name
1	:	15 Echoes
2	:	60 Doubletrk
3	:	15 Echoes
	:	---
128	:	2 Trnsp. 5th

**Selecting MEP4
Memories by Program
in RUN Mode**

You can make use of this program change table while in RUN mode. By holding down **GROUP SELECT**, you can use   to step through the program change table.





The LCD will display the program number, memory number and memory name, like this.

128:60_Echoes_...

(See also p.40 on how to use a footswitch to select memories by program number.)

**Initialize Program
Assignment Table**

Using this function will set the program assignment table to 1:1, 2:2 3:3, 4:4, ... 60:60, 61:1, ... etc. Use the   switches to get the

Init_ASSIGN_#_?_

display and press **INC**. The MEP4 will ask you

_Are_You_Sure_?_

so replay "Yes" again. The LCD will read

_*_Completed!*_

for about a second and then return to the previous display.

**FOOT SWITCH
ASSIGN**

FOOT-SW_ASSIGN_..



Func(MEMORY-INC) ← Func(PRGRM-INC) ← Func(RCV.MD-SEL)

You can use a footswitch plugged into the jack on the back panel in three ways.

Memory Increment

Func(MEMORY-INC)

Each time you press the footswitch, the next MEP4 memory will be selected. When you get to memory 60, it will wrap around again to 1.

Program Increment

Func(PRGRAM-INC)

Each time you press the footswitch, the next MEP4 memory in the Program Assignment Table (see p.39) will be selected. When the program number reaches 128, it will wrap around again to 1. When this mode is selected, the LCD will display the memory name like this,

No: 1__Echoes_..

with "No:" instead of the usual "No." This indicates that you are selecting MEP4 memories by Program Assignment Table. By pressing **GROUP SELECT** you can see what program number you have come to. Of course, you can still select memories in the usual way using **DEC** **INC**.

Receive Mode Select

Func(RCV.MD-SEL)

This lets you select the Program Change Receive Mode at any time. When this mode has been set and you are in RUN mode, everytime the footswitch is pressed the LCD will alternate between

No. 1 .. Echoes ...

and

No. 1 .. Echoes ...

When the LCD shows "No.", incoming MIDI Program Change messages will select the MEP4 memory number, and when it shows "No:", they will select the MEP4 memory number in the Program Assignment Table. (A footswitch is not included with the MEP4. Use an on/off switch such as the FC-4 or FC-5)

MIDI MONITOR

This function lets you monitor the output of each processor.

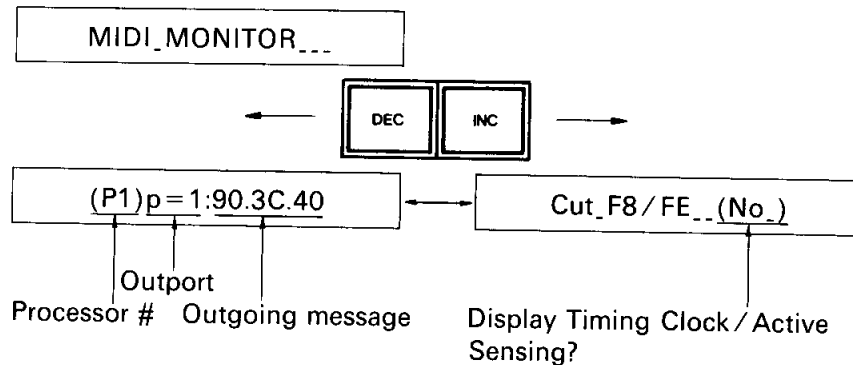

Select the processor (P1-P4) you want to monitor. The "p=" indicates the Output Port that the processor is assigned to. If the processor is turned off, the LCD will show "p= *".

By selecting "Cut F8/FE (Yes)", you can ignore Timing Clock messages (F8) and Active Sensing messages (FE). These messages come so fast and so frequently that you will not be able to read anything else. (See p.68)

Note:

The MIDI Monitor will not display System Exclusive messages (F0 ...F7).

MIDI BULK DUMP

This function lets you dump the entire contents of the MEP4 memory via the MIDI OUT 1-4. The same bulk data is sent from each MIDI OUT.

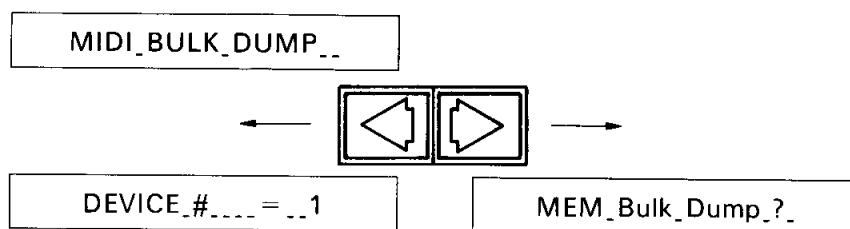

Reception Conditions

When the receiving MEP4 has finished taking in the bulk data, it will display

BULK_DATA_RCVD_!

no matter what mode it is in. Then, when it receives a Program Change message, it will return to the normal display.

If the bulk data was received incorrectly, it will display

MIDI_DATA_ERROR!

and if Memory Protect is on

Memory_Protected

When it receives a Program Change message (or a Mode switch or Foot switch is pressed) it will return to the normal display. (When bulk data with a different device number is received, it is sent on unchanged and nothing is displayed.)

Device Number

You can select Device # to be ALL or 1-16. Device number is a kind of channel number inside Yamaha System Exclusive messages. The MEP4 will receive bulk data only if it has a matching Device number. When "ALL" is selected, the MEP4 will receive bulk data of any Device number.

Memory Bulk Dump

This can be used to copy the memory of one MEP4 to the memory of another MEP4. Connect the MIDI OUT of the transmitting MEP4 to the MIDI IN of the receiving MEP4, and turn the receiving MEP4's memory protect off (p.35). Make sure the Device # for each MEP4 matches, or is set to "ALL." (When the Device # is "ALL", bulk data is sent as Device # 1.)

Get the "MEM Bulk Dump?" display on the transmitting MEP4 and press **[INC]**. The LCD will read

Now Transmitting

for a second or two and then return to the "MEM Bulk Dump?" display. (Bulk data is also dumped when a MIDI Dump Request is received. See p.69) Remember that the dumped data does not "disappear" from the transmitting MEP4, but is rather "copied" out.

Transmission Conditions

This bulk data is sent out of all processors who's Message Filter is set to pass system messages.

If no processors are set to pass system messages, the LCD will warn "Assign Output!" and not send anything.

Contents of Bulk Dump

The bulk data consists of the following:

- a. Data of all 60 memories
- b. Assign table for program changes 1-128
- c. Program receive yes/no and channel
- d. Program change receive mode
- e. Foot switch function

For the MIDI format of the bulk data, see p.69.

MEP4 bulk data includes the MIDI reception channel. This means that the MEP4 program change receive channel may change as a result of receiving a bulk dump. See p. 37.

EXAMPLE SETUP A (MEP4 + DX7 + TX7)

Here are some more complicated setups. We will assume that you have read through the manual to this point, tried out the simple setup example, and that you understand the basic operation of the MEP4. If you have problems setting up the examples, refer back to EDIT mode (p.19).

As shown in the diagram, connect the DX7 MIDI OUT to the MEP4 MIDI IN, the MEP4 MIDI OUT 1 to the TX7 MIDI IN, and the MEP4 MIDI OUT2 to the DX7 MIDI IN. Set the DX7 to receive and transmit on channel 1 and set the TX7 to receive on channel 1 also. (Refer to the owner's manuals for each device.)

Example A1 Harp Arp

				Harp Arp																			
				1	2	3	4																
				ON/OFF	ON/OFF	ON/OFF	ON/OFF	Each note produces a harp arpeggio															
DATA PRESETTER				DATA PRESETTER				DATA PRESETTER															
PROGRAM	(ON / OFF)	nn	40	PROGRAM	(ON / OFF)			PROGRAM	(ON / OFF)														
PITCH	(ON / OFF)	00	40	PITCH	(ON / OFF)			PITCH	(ON / OFF)														
CONTROL 1	(ON / OFF)	01	00	CONTROL 1	(ON / OFF)			CONTROL 1	(ON / OFF)														
CONTROL 2	(ON / OFF)	07	7F	CONTROL 2	(ON / OFF)			CONTROL 2	(ON / OFF)														
CHANNEL FILTER				CHANNEL FILTER				CHANNEL FILTER															
OMNI : ON / OFF				OMNI : ON / OFF				OMNI : ON / OFF															
1	2	3	4	5	6	7	8	1	2	3	4	5	6	7	8	1	2	3	4	5	6	7	8
9	10	11	12	13	14	15	16	9	10	11	12	13	14	15	16	9	10	11	12	13	14	15	16
MESSAGE FILTER				MESSAGE FILTER				MESSAGE FILTER															
NOTE OFF	ON / OFF			NOTE OFF	ON / OFF			NOTE OFF	ON / OFF														
NOTE ON	ON / OFF			NOTE ON	ON / OFF			NOTE ON	ON / OFF														
POLY A. TOUCH	ON / OFF			POLY A. TOUCH	ON / OFF			POLY A. TOUCH	ON / OFF														
CONTROL NO.	ALL / OFF			CONTROL NO.	ALL / ***			CONTROL NO.	ALL / ***														
PROGRAM CHANGE	ON / OFF			PROGRAM CHANGE	ON / OFF			PROGRAM CHANGE	ON / OFF														
CH A. TOUCH	ON / OFF			CH A. TOUCH	ON / OFF			CH A. TOUCH	ON / OFF														
PITCH BEND	ON / OFF			PITCH BEND	ON / OFF			PITCH BEND	ON / OFF														
CH MODE MES.	ON / OFF			CH MODE MES.	ON / OFF			CH MODE MES.	ON / OFF														
SYSTEM MES.	ON / OFF			SYSTEM MES.	ON / OFF			SYSTEM MES.	ON / OFF														
DATA MODIFIER				DATA MODIFIER				DATA MODIFIER															
0	MSG	: 9n, xx, yy		0	MSG	: 9n, xx, yy		0	MSG	: 9n, xx, yy													
1	OFS	: xx, V= +7		1	OFS	: xx, V= +10		1	OFS	: xx, V= +12													
2	:			2	:			2	:														
3	:			3	:			3	:														
4	:			4	:			4	:														
DELAY PROCESSOR				DELAY PROCESSOR				DELAY PROCESSOR															
DELAY TIME		150		DELAY TIME		300		DELAY TIME		450													
OUTPUT ASSIGNER				OUTPUT ASSIGNER				OUTPUT ASSIGNER															
OUT-CH ASSIGN		1		OUT-CH ASSIGN		1		OUT-CH ASSIGN		1													
OUT-CH OFFSET		0		OUT-CH OFFSET		0		OUT-CH OFFSET		0													
OUTPORT ASSIGN		1		OUTPORT ASSIGN		1		OUTPORT ASSIGN		1													

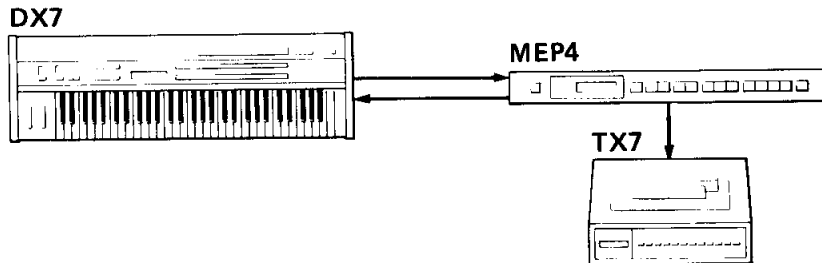

Each note you play on the DX7 will produce three delayed notes from the TX7.

Processor 1: Along with the usual Pitch Bender, Modulation Wheel and Volume initialization messages, the Data Presetter will send a Program Change to select a Harp voice for the TX7. Naturally, you will have to specify a program number (nn) that contains a harp-like voice (or whatever you want). All Note On messages are modified by adding 7 to the note number. Then the modified Note On messages along with the unchanged controller messages are delayed for 150 msec and sent on channel 1 out of output 1. Since the Channel Filter is set to reject Program Changes, you can select programs on the DX7 and still have the same Harp arpeggio.

Processor 2: Since we have already sent initialization messages from processor 1, we don't need to do it again. This time we will accept only Note On/Off messages. The Note On messages are modified by adding 10 to the note number and sent out after a 300 msec delay.

Processor 3: The same as processor 2, but with a 450 msec delay, and adding 12 to the note number.

Processor 4: This has been left open for you to experiment with, perhaps by adding an additional delayed note.

DATA PRESETTER							
PROGRAM (ON / OFF)							
PITCH (ON / OFF)							
CONTROL 1 (ON / OFF)							
CONTROL 2 (ON / OFF)							
CHANNEL FILTER							
OMNI: ON / OFF							
1	2	3	4	5	6	7	8
9	10	11	12	13	14	15	16
MESSAGE FILTER							
NOTE OFF	ON / OFF						
NOTE ON	ON / OFF						
POLY A. TOUCH	ON / OFF						
CONTROL NO.	ALL /						
PROGRAM CHANGE	ON / OFF						
CH A. TOUCH	ON / OFF						
PITCH BEND	ON / OFF						
CH MODE MES.	ON / OFF						
SYSTEM MES.	ON / OFF						
DATA MODIFIER							
0	MSG :						
1	:						
2	:						
3	:						
4	:						
DELAY PROCESSOR							
DELAY TIME							
OUTPUT ASSIGNER							
OUT-CH ASSIGN							
OUT-CH OFFSET							
OUTPORT ASSIGN							

Example A2 Fat Synth

				Fat Synth																			
				1	2	3	4																
				<input checked="" type="radio"/> ON / <input type="radio"/> OFF	<input checked="" type="radio"/> ON / <input type="radio"/> OFF	<input checked="" type="radio"/> ON / <input type="radio"/> OFF	<input checked="" type="radio"/> ON / <input type="radio"/> OFF	Below middle C → Octave down (output 2) Unchanged (output 1) Middle C and above → Octave up (Output 1)															
DATA PRESETTER				DATA PRESETTER				DATA PRESETTER															
PROGRAM	(<input checked="" type="radio"/> ON / <input type="radio"/> OFF)			PROGRAM	(<input checked="" type="radio"/> ON / <input type="radio"/> OFF)			PROGRAM	(<input checked="" type="radio"/> ON / <input type="radio"/> OFF)														
PITCH	(<input checked="" type="radio"/> ON / <input type="radio"/> OFF)	00	40	PITCH	(<input checked="" type="radio"/> ON / <input type="radio"/> OFF)	00	40	PITCH	(<input checked="" type="radio"/> ON / <input type="radio"/> OFF)														
CONTROL 1	(<input checked="" type="radio"/> ON / <input type="radio"/> OFF)	01	00	CONTROL 1	(<input checked="" type="radio"/> ON / <input type="radio"/> OFF)	01	00	CONTROL 1	(<input checked="" type="radio"/> ON / <input type="radio"/> OFF)														
CONTROL 2	(<input checked="" type="radio"/> ON / <input type="radio"/> OFF)	07	7F	CONTROL 2	(<input checked="" type="radio"/> ON / <input type="radio"/> OFF)	07	7F	CONTROL 2	(<input checked="" type="radio"/> ON / <input type="radio"/> OFF)														
CHANNEL FILTER				CHANNEL FILTER				CHANNEL FILTER															
OMNI : <input checked="" type="radio"/> ON / <input type="radio"/> OFF				OMNI : <input checked="" type="radio"/> ON / <input type="radio"/> OFF				OMNI : <input checked="" type="radio"/> ON / <input type="radio"/> OFF															
1	2	3	4	5	6	7	8	1	2	3	4	5	6	7	8	1	2	3	4	5	6	7	8
9	10	11	12	13	14	15	16	9	10	11	12	13	14	15	16	9	10	11	12	13	14	15	16
MESSAGE FILTER				MESSAGE FILTER				MESSAGE FILTER															
NOTE OFF	<input checked="" type="radio"/> ON / <input type="radio"/> OFF			NOTE OFF	<input checked="" type="radio"/> ON / <input type="radio"/> OFF			NOTE OFF	<input checked="" type="radio"/> ON / <input type="radio"/> OFF														
NOTE ON	<input checked="" type="radio"/> ON / <input type="radio"/> OFF			NOTE ON	<input checked="" type="radio"/> ON / <input type="radio"/> OFF			NOTE ON	<input checked="" type="radio"/> ON / <input type="radio"/> OFF														
POLY A. TOUCH	ON / <input checked="" type="radio"/> OFF			POLY A. TOUCH	ON / <input checked="" type="radio"/> OFF			POLY A. TOUCH	ON / <input checked="" type="radio"/> OFF														
CONTROL NO.	ALL / <input checked="" type="radio"/> ***			CONTROL NO.	ALL / <input checked="" type="radio"/> ***			CONTROL NO.	ALL / <input checked="" type="radio"/> ***														
PROGRAM CHANGE	ON / <input checked="" type="radio"/> OFF			PROGRAM CHANGE	ON / <input checked="" type="radio"/> OFF			PROGRAM CHANGE	ON / <input checked="" type="radio"/> OFF														
CH A. TOUCH	ON / <input checked="" type="radio"/> OFF			CH A. TOUCH	ON / <input checked="" type="radio"/> OFF			CH A. TOUCH	ON / <input checked="" type="radio"/> OFF														
PITCH BEND	ON / <input checked="" type="radio"/> OFF			PITCH BEND	ON / <input checked="" type="radio"/> OFF			PITCH BEND	ON / <input checked="" type="radio"/> OFF														
CH MODE MES.	ON / <input checked="" type="radio"/> OFF			CH MODE MES.	ON / <input checked="" type="radio"/> OFF			CH MODE MES.	ON / <input checked="" type="radio"/> OFF														
SYSTEM MES.	ON / <input checked="" type="radio"/> OFF			SYSTEM MES.	ON / <input checked="" type="radio"/> OFF			SYSTEM MES.	ON / <input checked="" type="radio"/> OFF														
DATA MODIFIER				DATA MODIFIER				DATA MODIFIER															
0	MSG	: 9n, xx, yy		0	MSG	: ***		0	MSG	: 9n, xx, yy													
1	LIM	: xx, 00 ≤ D ≤ 3B		1	:			1	LIM	: xx, 3C ≤ D ≤ 7F													
2	OFS	: xx, V = +12		2	:			2	OFS	: xx, V = +12													
3	:			3	:			3	:														
4	:			4	:			4	:														
DELAY PROCESSOR				DELAY PROCESSOR				DELAY PROCESSOR															
DELAY TIME		0		DELAY TIME		0		DELAY TIME		0													
OUTPUT ASSIGNER				OUTPUT ASSIGNER				OUTPUT ASSIGNER															
OUT-CH ASSIGN		1		OUT-CH ASSIGN		1		OUT-CH ASSIGN		1													
OUT-CH OFFSET		0		OUT-CH OFFSET		0		OUT-CH OFFSET		0													
OUTPORT ASSIGN		2		OUTPORT ASSIGN		1		OUTPORT ASSIGN		1													



This example produces an especially thick, octave-doubled sound that is excellent for strings.

DATA PRESETTER							
PROGRAM (ON / OFF)							
PITCH (ON / OFF)							
CONTROL 1 (ON / OFF)							
CONTROL 2 (ON / OFF)							
CHANNEL FILTER							
OMNI : ON / OFF							
1	2	3	4	5	6	7	8
9	10	11	12	13	14	15	16
MESSAGE FILTER							
NOTE OFF	ON / OFF						
NOTE ON	ON / OFF						
POLY A. TOUCH	ON / OFF						
CONTROL NO.	ALL /						
PROGRAM CHANGE	ON / OFF						
CH A. TOUCH	ON / OFF						
PITCH BEND	ON / OFF						
CH MODE MES.	ON / OFF						
SYSTEM MES.	ON / OFF						
DATA MODIFIER							
0	MSG :						
1	:						
2	:						
3	:						
4	:						
DELAY PROCESSOR							
DELAY TIME							
OUTPUT ASSIGNER							
OUT-CH ASSIGN							
OUT-CH OFFSET							
OUTPORT ASSIGN							

Processor 1: This processor will send an octave lower note back to the DX7. We will also send the usual initialization message (Data Presetter). Since the DX7 already has "received" its own controller messages, we don't need to re-send them via MIDI. All we will send is Note On/Off. So as not to make the sound too bottom-heavy, we will restrict the octave doubling to notes below middle C (LIM). Then we will subtract 12 from the note number, and send it from output 2 (to which the DX7 is connected).

Processor 2: This processor will send the unchanged note and controller messages unchanged to the TX7, providing a simple doubling effect. (Data Modifier "O: MSG: ***" indicates no modification.)

Processor 3: This processor will send an octave higher note to the TX7 (OFS). Again, in order to keep the sound from getting too muddy, we will restrict the octave doubling to notes above middle C (LIM).

Processor 4: This has been left for you to experiment with. Remember that the DX7 and TX7 can each produce up to 16 notes simultaneously. If for every incoming Note On messages you send 4 outgoing Note On messages, you will have, in effect, only 4-note polyphony.

Example A3 Bend UP Dn

				Bend Up Dn																			
				1	2	3	4	Aftertouch → Bend up (Output 2) Bend down (Output 1)															
				<input checked="" type="radio"/> ON / <input type="radio"/> OFF	<input checked="" type="radio"/> ON / <input type="radio"/> OFF	<input type="radio"/> ON / <input checked="" type="radio"/> OFF	<input type="radio"/> ON / <input checked="" type="radio"/> OFF																
DATA PRESETTER				DATA PRESETTER				DATA PRESETTER															
PROGRAM	(ON / <input checked="" type="radio"/> OFF)			PROGRAM	(ON / <input checked="" type="radio"/> OFF)			PROGRAM	(ON / OFF)														
PITCH	(<input checked="" type="radio"/> ON / OFF)	00	40	PITCH	(<input checked="" type="radio"/> ON / OFF)	00	40	PITCH	(ON / OFF)														
CONTROL 1	(<input checked="" type="radio"/> ON / OFF)	01	00	CONTROL 1	(<input checked="" type="radio"/> ON / OFF)	01	00	CONTROL 1	(ON / OFF)														
CONTROL 2	(<input checked="" type="radio"/> ON / OFF)	07	7F	CONTROL 2	(<input checked="" type="radio"/> ON / OFF)	07	7F	CONTROL 2	(ON / OFF)														
CHANNEL FILTER				CHANNEL FILTER				CHANNEL FILTER															
OMNI : <input checked="" type="radio"/> ON / <input type="radio"/> OFF				OMNI : <input checked="" type="radio"/> ON / <input type="radio"/> OFF				OMNI : ON / OFF															
1	2	3	4	5	6	7	8	1	2	3	4	5	6	7	8	1	2	3	4	5	6	7	8
9	10	11	12	13	14	15	16	9	10	11	12	13	14	15	16	9	10	11	12	13	14	15	16
MESSAGE FILTER				MESSAGE FILTER				MESSAGE FILTER															
NOTE OFF		ON / <input checked="" type="radio"/> OFF		NOTE OFF		<input checked="" type="radio"/> ON / OFF		NOTE OFF		ON / OFF													
NOTE ON		ON / <input checked="" type="radio"/> OFF		NOTE ON		<input checked="" type="radio"/> ON / <input type="radio"/> OFF		NOTE ON		ON / OFF													
POLY A. TOUCH		ON / <input checked="" type="radio"/> OFF		POLY A. TOUCH		ON / <input checked="" type="radio"/> OFF		POLY A. TOUCH		ON / OFF													
CONTROL NO.		ALL / *.*.*		CONTROL NO.		<input checked="" type="radio"/> ALL /		CONTROL NO.		ALL /													
PROGRAM CHANGE		ON / <input checked="" type="radio"/> OFF		PROGRAM CHANGE		<input checked="" type="radio"/> ON / OFF		PROGRAM CHANGE		ON / OFF													
CH A. TOUCH		<input checked="" type="radio"/> ON / OFF		CH A. TOUCH		<input checked="" type="radio"/> ON / OFF		CH A. TOUCH		ON / OFF													
PITCH BEND		ON / <input checked="" type="radio"/> OFF		PITCH BEND		ON / <input checked="" type="radio"/> OFF		PITCH BEND		ON / OFF													
CH MODE MES.		ON / <input checked="" type="radio"/> OFF		CH MODE MES.		ON / <input checked="" type="radio"/> OFF		CH MODE MES.		ON / OFF													
SYSTEM MES.		ON / <input checked="" type="radio"/> OFF		SYSTEM MES.		ON / <input checked="" type="radio"/> OFF		SYSTEM MES.		ON / OFF													
DATA MODIFIER				DATA MODIFIER				DATA MODIFIER															
0	MSG	:	Dn, xx	0	MSG	:	Dn, xx	0	MSG	:													
1	OFS	:	xx, V = +64	1	OFS	:	xx, V = +64	1		:													
2	CNV	:	-- → En, 00, xx	2	REV	:	xx, FIX = 40	2		:													
3		:		3	CNV	:	-- → En, 00, xx	3		:													
4		:		4		:		4		:													
DELAY PROCESSOR				DELAY PROCESSOR				DELAY PROCESSOR															
DELAY TIME			0	DELAY TIME			0	DELAY TIME															
OUTPUT ASSIGNER				OUTPUT ASSIGNER				OUTPUT ASSIGNER															
OUT-CH ASSIGN			1	OUT-CH ASSIGN			1	OUT-CH ASSIGN															
OUT-CH OFFSET			0	OUT-CH OFFSET			0	OUT-CH OFFSET															
OUTPORT ASSIGN			2	OUTPORT ASSIGN			1	OUTPORT ASSIGN															

When you press down on the DX7 keyboard, the DX7 will pitch-bend up and the TX7 will pitch-bend down. (You will have to set the Pitch Bend range to a non-zero value. See the DX7 and TX7 manuals.)

Processor 1: This will send Pitch Bend messages back to the DX7. We will accept only Channel Aftertouch messages and convert these into Pitch Bend messages with the original Aftertouch data (first byte) sent out as the Pitch Bend second byte (MSB : most significant byte). Yamaha synthesizers ignore the LSB (least significant byte) of Pitch Bend messages, so we will send 00 for all Pitch Bend LSBs. Notice that we must add 64 (decimal) to the Aftertouch data in order to bring the Pitch Bender to center position.

Processor 2: This will send the DX7's note and controller messages unchanged to the TX7, and also send the "created" Pitch Bend messages. This time however, we will reverse (REV) the pitch bend data byte to make it bend down.

Processor 3 and 4 : Not used.

Note: By adjusting the pitch bend range of the TX7 and DX7 you can set the width of the effect.



DATA PRESETTER							
PROGRAM (ON / OFF)							
PITCH (ON / OFF)							
CONTROL 1 (ON / OFF)							
CONTROL 2 (ON / OFF)							
CHANNEL FILTER							
OMNI : ON / OFF							
1	2	3	4	5	6	7	8
9	10	11	12	13	14	15	16
MESSAGE FILTER							
NOTE OFF	ON / OFF						
NOTE ON	ON / OFF						
POLY A. TOUCH	ON / OFF						
CONTROL NO.	ALL /						
PROGRAM CHANGE	ON / OFF						
CH A. TOUCH	ON / OFF						
PITCH BEND	ON / OFF						
CH MODE MES.	ON / OFF						
SYSTEM MES.	ON / OFF						
DATA MODIFIER							
0	MSG :						
1	:						
2	:						
3	:						
4	:						
DELAY PROCESSOR							
DELAY TIME							
OUTPUT ASSIGNER							
OUT-CH ASSIGN							
OUT-CH OFFSET							
OUTPORT ASSIGN							

EXAMPLE SETUP B (MEP4 + KX88 + TX816 + RX11)

Here are some examples of how the MEP4 can be used in a larger setup. As shown in the diagram, connect the KX88 MIDI OUT to the MEP4 MIDI IN, the MEP4 MIDI OUT 1 to the TX816 MIDI IN, and the MEP4 MIDI OUT 2 to the RX11 MIDI IN.

Example B1 Drum Kit

MIDI IN NAME		Drum Kit					
MIDI IN ON/OFF		1	2	3	4	Sustain Pedal = Bass Drum Keyboard left side = Snare Keyboard right side = High Hat	
		<input checked="" type="checkbox"/> ON / OFF	<input checked="" type="checkbox"/> ON / OFF	<input checked="" type="checkbox"/> ON / OFF	<input checked="" type="checkbox"/> ON / OFF		
DATA PRESETTER		DATA PRESETTER		DATA PRESETTER			
PROGRAM	(ON / <input checked="" type="checkbox"/> OFF)	PROGRAM	(ON / <input checked="" type="checkbox"/> OFF)	PROGRAM	(ON / <input checked="" type="checkbox"/> OFF)		
PITCH	(ON / <input checked="" type="checkbox"/> OFF)	PITCH	(ON / <input checked="" type="checkbox"/> OFF)	PITCH	(ON / <input checked="" type="checkbox"/> OFF)		
CONTROL 1	(ON / <input checked="" type="checkbox"/> OFF)	CONTROL 1	(ON / <input checked="" type="checkbox"/> OFF)	CONTROL 1	(ON / <input checked="" type="checkbox"/> OFF)		
CONTROL 2	(ON / <input checked="" type="checkbox"/> OFF)	CONTROL 2	(ON / <input checked="" type="checkbox"/> OFF)	CONTROL 2	(ON / <input checked="" type="checkbox"/> OFF)		
CHANNEL FILTER		CHANNEL FILTER		CHANNEL FILTER			
OMNI : <input checked="" type="checkbox"/> ON / OFF		OMNI : <input checked="" type="checkbox"/> ON / OFF		OMNI : <input checked="" type="checkbox"/> ON / OFF			
1	2	3	4	5	6	7	8
9	10	11	12	13	14	15	16
MESSAGE FILTER		MESSAGE FILTER		MESSAGE FILTER			
NOTE OFF	ON / <input checked="" type="checkbox"/> OFF	NOTE OFF	<input checked="" type="checkbox"/> ON / OFF	NOTE OFF	<input checked="" type="checkbox"/> ON / OFF		
NOTE ON	ON / <input checked="" type="checkbox"/> OFF	NOTE ON	<input checked="" type="checkbox"/> ON / OFF	NOTE ON	<input checked="" type="checkbox"/> ON / OFF		
POLY A. TOUCH	ON / <input checked="" type="checkbox"/> OFF	POLY A. TOUCH	ON / <input checked="" type="checkbox"/> OFF	POLY A. TOUCH	ON / <input checked="" type="checkbox"/> OFF		
CONTROL NO.	ALL / 40, **	CONTROL NO.	ALL / **, **	CONTROL NO.	ALL / **, **		
PROGRAM CHANGE	ON / <input checked="" type="checkbox"/> OFF	PROGRAM CHANGE	ON / <input checked="" type="checkbox"/> OFF	PROGRAM CHANGE	ON / <input checked="" type="checkbox"/> OFF		
CH A. TOUCH	ON / <input checked="" type="checkbox"/> OFF	CH A. TOUCH	ON / <input checked="" type="checkbox"/> OFF	CH A. TOUCH	ON / <input checked="" type="checkbox"/> OFF		
PITCH BEND	ON / <input checked="" type="checkbox"/> OFF	PITCH BEND	ON / <input checked="" type="checkbox"/> OFF	PITCH BEND	ON / <input checked="" type="checkbox"/> OFF		
CH MODE MES.	ON / <input checked="" type="checkbox"/> OFF	CH MODE MES.	ON / <input checked="" type="checkbox"/> OFF	CH MODE MES.	ON / <input checked="" type="checkbox"/> OFF		
SYSTEM MES.	ON / <input checked="" type="checkbox"/> OFF	SYSTEM MES.	ON / <input checked="" type="checkbox"/> OFF	SYSTEM MES.	ON / <input checked="" type="checkbox"/> OFF		
DATA MODIFIER		DATA MODIFIER		DATA MODIFIER			
0	MSG : 8n, 40, yy	0	MSG : 9n, xx, yy	0	MSG : 9n, xx, yy		
1	CNV : -- → 9n, 2c, yy	1	LIM : xx, 00 ≤ 0 ≤ 3B	1	LIM : xx, 3c ≤ D ≤ 7F		
2	:	2	CNV : → 9n, 31, yy	2	LIM : yy, 00 ≤ D ≤ 63		
3	:	3	:	3	CNV : → 9n, 39, yy		
4	:	4	:	4	:		
DELAY PROCESSOR		DELAY PROCESSOR		DELAY PROCESSOR			
DELAY TIME	0	DELAY TIME	0	DELAY TIME	0		
OUTPUT ASSIGNER		OUTPUT ASSIGNER		OUTPUT ASSIGNER			
OUT-CH ASSIGN	1	OUT-CH ASSIGN	1	OUT-CH ASSIGN	1		
OUT-CH OFFSET	0	OUT-CH OFFSET	0	OUT-CH OFFSET	0		
OUTPORT ASSIGN	2	OUTPORT ASSIGN	2	OUTPORT ASSIGN	2		

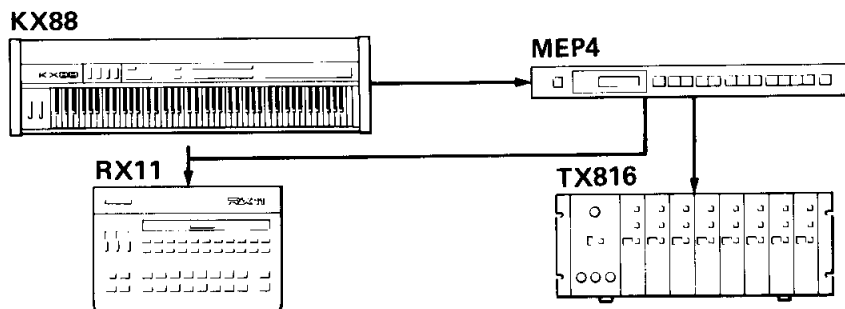

This will let you play the RX instruments from the KX keyboard. We assume that the RX is set to receive Note On/Off information on channel 1, and that the MIDI key number for each instrument is as follows; Bass Drum = 2C, Snare = 31, High Hat = 39, and High Hat Open = 3B. (If the key numbers on your rhythm machine are fixed and cannot be changed, substitute the appropriate key numbers xx for Data Modifier CNV → 9n. xx. yy.)

Processor 1: This accepts only Control Change # 40 (Sustain On/Off) and converts it into a Note On message for note number 2C, which corresponds to the RX Bass Drum. When the sustain pedal is pressed, the KX sends a Control Change message #40 with data of 7F (sustain pedal on), which is sent out as a velocity of 7F (Note On). When the sustain pedal is released, the velocity will be 0 (Note Off).

Processor 2: This accepts Note On/Off messages below middle C (limit the note number), and converts them into Note On messages for note number 31, which corresponds to the RX Snare. The velocity will be passed on unchanged, so if you play a note strongly, the Snare will be loud.

Processor 3: This accepts notes from above middle C and converts them into Note On messages for note number 39, which corresponds to the RX High Hat. Notice that in Data Modifier step 2 we limit the notes to those with velocity of 63 and below. Notes played strongly (ie. velocity of above 63) will not make the High Hat sound.

Processor 4: This is the same as processor 3 except that it will process only strongly played notes (ie. velocity of above 63), and converts them into Note On messages for note number 3B (Open High Hat). This means that by playing softly or strongly above middle C, you can play Closed or Open High Hat.

(Play strongly for Open High Hat)	
DATA PRESETTER	
PROGRAM	(ON / <input checked="" type="radio"/> OFF)
PITCH	(ON / <input checked="" type="radio"/> OFF)
CONTROL 1	(ON / <input checked="" type="radio"/> OFF)
CONTROL 2	(ON / <input checked="" type="radio"/> OFF)
CHANNEL FILTER	
OMNI	<input checked="" type="radio"/> ON / OFF
1	2
3	4
5	6
7	8
9	10
11	12
13	14
15	16
MESSAGE FILTER	
NOTE OFF	<input checked="" type="radio"/> ON / OFF
NOTE ON	<input checked="" type="radio"/> ON / OFF
POLY A. TOUCH	ON / <input checked="" type="radio"/> OFF
CONTROL NO.	ALL / **/**
PROGRAM CHANGE	ON / <input checked="" type="radio"/> OFF
CH A. TOUCH	ON / <input checked="" type="radio"/> OFF
PITCH BEND	ON / <input checked="" type="radio"/> OFF
CH MODE MES.	ON / <input checked="" type="radio"/> OFF
SYSTEM MES.	ON / <input checked="" type="radio"/> OFF
DATA MODIFIER	
0	MSG : 9n, xx, yy
1	IM : xx, 3C ≤ D ≤ 7E
2	LIM : yy, 64 ≤ D ≤ 7F
3	CNV : → 9n, 3B, 7F
4	:
DELAY PROCESSOR	
DELAY TIME	0
OUTPUT ASSIGNER	
OUT-CH ASSIGN	1
OUT-CH OFFSET	0
OUTPORT ASSIGN	2

Example B2 4-way Vol

				4-Way Vol																			
				1	2	3	4	KX in Dual mode, CS1, CS2 = Volume A, B (Channel A, B = 1, 2) CS3, CS4 = Control CS1 ~ 4 Control Volume for Channels 1 ~															
				<input checked="" type="radio"/> ON / OFF	<input checked="" type="radio"/> ON / OFF	<input checked="" type="radio"/> ON / OFF	<input checked="" type="radio"/> ON / OFF																
DATA PRESETTER				DATA PRESETTER				DATA PRESETTER															
PROGRAM	(ON / <input checked="" type="radio"/> OFF)			PROGRAM	(ON / <input checked="" type="radio"/> OFF)			PROGRAM	(ON / <input checked="" type="radio"/> OFF)														
PITCH	(<input checked="" type="radio"/> ON / OFF)	00	40	PITCH	(<input checked="" type="radio"/> ON / OFF)	00	40	PITCH	(<input checked="" type="radio"/> ON / OFF)	00	40												
CONTROL 1	(<input checked="" type="radio"/> ON / OFF)	01	00	CONTROL 1	(<input checked="" type="radio"/> ON / OFF)	01	00	CONTROL 1	(<input checked="" type="radio"/> ON / OFF)	01	00												
CONTROL 2	(<input checked="" type="radio"/> ON / OFF)	07	7F	CONTROL 2	(<input checked="" type="radio"/> ON / OFF)	07	7F	CONTROL 2	(<input checked="" type="radio"/> ON / OFF)	07	7F												
CHANNEL FILTER				CHANNEL FILTER				CHANNEL FILTER															
OMNI : <input checked="" type="radio"/> ON / OFF				OMNI : ON / <input checked="" type="radio"/> OFF				OMNI : ON / <input checked="" type="radio"/> OFF															
1	2	3	4	5	6	7	8	①	2	3	4	5	6	7	8	1	②	3	4	5	6	7	8
9	10	11	12	13	14	15	16	9	10	11	12	13	14	15	16	9	10	11	12	13	14	15	16
MESSAGE FILTER				MESSAGE FILTER				MESSAGE FILTER															
NOTE OFF	<input checked="" type="radio"/> ON / OFF			NOTE OFF	<input checked="" type="radio"/> ON / OFF			NOTE OFF	<input checked="" type="radio"/> ON / OFF														
NOTE ON	<input checked="" type="radio"/> ON / OFF			NOTE ON	<input checked="" type="radio"/> ON / OFF			NOTE ON	<input checked="" type="radio"/> ON / OFF														
POLY A. TOUCH	<input checked="" type="radio"/> ON / <input checked="" type="radio"/> OFF			POLY A. TOUCH	<input checked="" type="radio"/> ON / <input checked="" type="radio"/> OFF			POLY A. TOUCH	<input checked="" type="radio"/> ON / <input checked="" type="radio"/> OFF														
CONTROL NO.	<input checked="" type="radio"/> ALL /			CONTROL NO.	ALL / 40,41			CONTROL NO.	ALL / 40,41														
PROGRAM CHANGE	<input checked="" type="radio"/> ON / OFF			PROGRAM CHANGE	<input checked="" type="radio"/> ON / OFF			PROGRAM CHANGE	<input checked="" type="radio"/> ON / OFF														
CH A. TOUCH	<input checked="" type="radio"/> ON / <input checked="" type="radio"/> OFF			CH A. TOUCH	<input checked="" type="radio"/> ON / <input checked="" type="radio"/> OFF			CH A. TOUCH	<input checked="" type="radio"/> ON / <input checked="" type="radio"/> OFF														
PITCH BEND	<input checked="" type="radio"/> ON / OFF			PITCH BEND	<input checked="" type="radio"/> ON / OFF			PITCH BEND	<input checked="" type="radio"/> ON / OFF														
CH MODE MES.	<input checked="" type="radio"/> ON / <input checked="" type="radio"/> OFF			CH MODE MES.	<input checked="" type="radio"/> ON / <input checked="" type="radio"/> OFF			CH MODE MES.	<input checked="" type="radio"/> ON / <input checked="" type="radio"/> OFF														
SYSTEM MES.	<input checked="" type="radio"/> ON / <input checked="" type="radio"/> OFF			SYSTEM MES.	<input checked="" type="radio"/> ON / <input checked="" type="radio"/> OFF			SYSTEM MES.	<input checked="" type="radio"/> ON / <input checked="" type="radio"/> OFF														
DATA MODIFIER				DATA MODIFIER				DATA MODIFIER															
0	MSG	: ***		0	MSG	: 9n, xx, yy		0	MSG	: 9n, xx, yy													
1	:			1	LIM	: xx, 00 ≤ D ≤ 3B		1	LIM	: xx, 3C ≤ D ≤ 7F													
2	:			2	:			2	:														
3	:			3	:			3	:														
4	:			4	:			4	:														
DELAY PROCESSOR				DELAY PROCESSOR				DELAY PROCESSOR															
DELAY TIME	0			DELAY TIME	0			DELAY TIME	0														
OUTPUT ASSIGNER				OUTPUT ASSIGNER				OUTPUT ASSIGNER															
OUT-CH ASSIGN	*			OUT-CH ASSIGN	3			OUT-CH ASSIGN	4														
OUT-CH OFFSET	0			OUT-CH OFFSET	0			OUT-CH OFFSET	0														
OUTPUT ASSIGN	1			OUTPUT ASSIGN	1			OUTPUT ASSIGN	1														

#10 A, B
4

DATA PRESETTER	
PROGRAM	(ON / <input checked="" type="radio"/> OFF)
PITCH	(ON / <input checked="" type="radio"/> OFF)
CONTROL 1	(ON / <input checked="" type="radio"/> OFF)
CONTROL 2	(ON / <input checked="" type="radio"/> OFF)
CHANNEL FILTER	
OMNI	<input checked="" type="radio"/> ON / OFF
1	2
3	4
5	6
7	8
9	10
11	12
13	14
15	16
MESSAGE FILTER	
NOTE OFF	ON / <input checked="" type="radio"/> OFF
NOTE ON	ON / <input checked="" type="radio"/> OFF
POLY A. TOUCH	ON / <input checked="" type="radio"/> OFF
CONTROL NO.	ALL / 10.**
PROGRAM CHANGE	ON / <input checked="" type="radio"/> OFF
CH A. TOUCH	ON / <input checked="" type="radio"/> OFF
PITCH BEND	ON / <input checked="" type="radio"/> OFF
CH MODE MES.	ON / <input checked="" type="radio"/> OFF
SYSTEM MES.	ON / <input checked="" type="radio"/> OFF
DATA MODIFIER	
0	MSG : Bn, 10, yy
1	.NV : Bn, 07, yy
2	:
3	:
4	:
DELAY PROCESSOR	
DELAY TIME	0
OUTPUT ASSIGNER	
OUT-CH ASSIGN	*
OUT-CH OFFSET	2
OUTPUT ASSIGN	1

This setup makes use of the KX front panel sliders CS 1-4 to independently control the volume of four separate tone generators. Set the KX in Dual mode, and make sure that CS1 and 2 are sending volume change messages for banks A and B (channels 1 and 2). Using CA mode of the KX (see the owner's manual), set CS3 and CS4 to send Control Change #10 on banks A and B. (Control Change #10 is unused, but we will convert it to Control Change #7 later). Set the TX816 modules 1-4 to accept channels 1-4. The entire KX keyboard will play modules 1 and 2, the upper part of the KX keyboard will play module 3 and the lower part will play module 4.

Processor 1: This will send the unchanged note and controller information (Data Modifier 0: ***) on the same channel it was received on. (The KX is transmitting on channels 1 and 2.)

Processor 2: This will accept note messages (below middle C) received on channel 1, and send them to module 3 on channel 3. We don't want to accept volume messages from channel 1, so specify only controllers 40 and 41 (sustain and portamento). Volume messages for channels 3 and 4 will be "created" in processor 4.

Processor 3: This will accept note messages (above middle C) received on channel 2, and send them to module 4 on channel 4. The rest is the same as processor 2.

Processor 4: This will convert the Control Change #10 messages received on channels 1 and 2 into Control Change #7 messages (volume) on channels 3 and 4 (output channel offset = 2). In this way, we can "get around" the limitation that the KX can send messages on only two channels at once.

Note: By using two MEP4s in parallel (connect the MIDI THRU to the MIDI IN of the second MEP4), we could have a complete 4-way split keyboard as well as 4-way volume control. Use two processors for each split; one to convert controller messages into volume and the other to limit the note area.

Sending continuous controller messages (aftertouch, volume, etc.) on many channels from a single output may cause an out-put overflow. (See p.34) When using setups like the one described above, it may be a good idea to assign each processor to its own output and connect it directly to the individual MIDI IN of each tone generator.

Example B3 Eko & Accnt

				Eko & Accnt																			
				1	2	3	4																
				<input checked="" type="radio"/> ON / <input type="radio"/> OFF	<input checked="" type="radio"/> ON / <input type="radio"/> OFF	<input checked="" type="radio"/> ON / <input type="radio"/> OFF	<input checked="" type="radio"/> ON / <input type="radio"/> OFF	A muted echo with Brass on accented notes															
DATA PRESETTER				DATA PRESETTER				DATA PRESETTER															
PROGRAM	(<input checked="" type="radio"/> ON / <input type="radio"/> OFF)			PROGRAM	(<input checked="" type="radio"/> ON / <input type="radio"/> OFF)			PROGRAM	(<input checked="" type="radio"/> ON / <input type="radio"/> OFF)	n													
PITCH	(<input checked="" type="radio"/> ON / <input type="radio"/> OFF)	00	40	PITCH	(<input checked="" type="radio"/> ON / <input type="radio"/> OFF)	00	40	PITCH	(<input checked="" type="radio"/> ON / <input type="radio"/> OFF)	00	40												
CONTROL 1	(<input checked="" type="radio"/> ON / <input type="radio"/> OFF)	01	00	CONTROL 1	(<input checked="" type="radio"/> ON / <input type="radio"/> OFF)	01	00	CONTROL 1	(<input checked="" type="radio"/> ON / <input type="radio"/> OFF)	01	00												
CONTROL 2	(<input checked="" type="radio"/> ON / <input type="radio"/> OFF)	07	7F	CONTROL 2	(<input checked="" type="radio"/> ON / <input type="radio"/> OFF)	07	7F	CONTROL 2	(<input checked="" type="radio"/> ON / <input type="radio"/> OFF)	07	7F												
CHANNEL FILTER				CHANNEL FILTER				CHANNEL FILTER															
OMNI : <input checked="" type="radio"/> ON / <input type="radio"/> OFF				OMNI : <input checked="" type="radio"/> ON / <input type="radio"/> OFF				OMNI : <input checked="" type="radio"/> ON / <input type="radio"/> OFF															
1	2	3	4	5	6	7	8	1	2	3	4	5	6	7	8	1	2	3	4	5	6	7	8
9	10	11	12	13	14	15	16	9	10	11	12	13	14	15	16	9	10	11	12	13	14	15	16
MESSAGE FILTER				MESSAGE FILTER				MESSAGE FILTER															
NOTE OFF	<input checked="" type="radio"/> ON / <input type="radio"/> OFF			NOTE OFF	<input checked="" type="radio"/> ON / <input type="radio"/> OFF			NOTE OFF	<input checked="" type="radio"/> ON / <input type="radio"/> OFF														
NOTE ON	<input checked="" type="radio"/> ON / <input type="radio"/> OFF			NOTE ON	<input checked="" type="radio"/> ON / <input type="radio"/> OFF			NOTE ON	<input checked="" type="radio"/> ON / <input type="radio"/> OFF														
POLY A. TOUCH	ON / <input checked="" type="radio"/> OFF			POLY A. TOUCH	ON / <input checked="" type="radio"/> OFF			POLY A. TOUCH	ON / <input checked="" type="radio"/> OFF														
CONTROL NO.	<input checked="" type="radio"/> ALL /			CONTROL NO.	<input checked="" type="radio"/> ALL /			CONTROL NO.	<input checked="" type="radio"/> ALL /														
PROGRAM CHANGE	<input checked="" type="radio"/> ON / <input type="radio"/> OFF			PROGRAM CHANGE	<input checked="" type="radio"/> ON / <input type="radio"/> OFF			PROGRAM CHANGE	ON / <input checked="" type="radio"/> OFF														
CH A. TOUCH	ON / <input checked="" type="radio"/> OFF			CH A. TOUCH	ON / <input checked="" type="radio"/> OFF			CH A. TOUCH	ON / <input checked="" type="radio"/> OFF														
PITCH BEND	ON / <input checked="" type="radio"/> OFF			PITCH BEND	ON / <input checked="" type="radio"/> OFF			PITCH BEND	ON / <input checked="" type="radio"/> OFF														
CH MODE MES.	ON / <input checked="" type="radio"/> OFF			CH MODE MES.	ON / <input checked="" type="radio"/> OFF			CH MODE MES.	ON / <input checked="" type="radio"/> OFF														
SYSTEM MES.	ON / <input checked="" type="radio"/> OFF			SYSTEM MES.	ON / <input checked="" type="radio"/> OFF			SYSTEM MES.	ON / <input checked="" type="radio"/> OFF														
DATA MODIFIER				DATA MODIFIER				DATA MODIFIER															
0	MSG	: ***		0	MSG	: 9n, xx, yy		0	MSG	: 9n, xx, yy													
1	:			1	EXP	: yy, R = 1/2		1	LIM	: yy, 4A ≤ D ≤ 7F													
2	:			2	:			2	:														
3	:			3	:			3	:														
4	:			4	:			4	:														
DELAY PROCESSOR				DELAY PROCESSOR				DELAY PROCESSOR															
DELAY TIME	0			DELAY TIME	400			DELAY TIME	0														
OUTPUT ASSIGNER				OUTPUT ASSIGNER				OUTPUT ASSIGNER															
OUT-CH ASSIGN	1			OUT-CH ASSIGN	2			OUT-CH ASSIGN	3														
OUT-CH OFFSET	0			OUT-CH OFFSET	0			OUT-CH OFFSET	0														
OUTPORT ASSIGN	1			OUTPORT ASSIGN	1			OUTPORT ASSIGN	1														

For each note received, this setup will produce a muted echo (decreased velocity), and for strongly played notes will produce an additional accent.

Processor 1: Here is used to send the unchanged note and controller messages.

Processor 2: Here we decrease the Note On velocity by 1/2 and send it out after a 400 msec delay.

Processor 3: Here we accept note and controller messages, and allow only strongly played notes (velocity above 4A) to pass. The Data Presetter can be used to preset this tone generator to whatever voice (program "n") you want to use as an accent.

Processor 4: Processor 3 will only produce Note On messages (velocity above 4A). So, here we will pass on the Note Off messages (velocity 0).

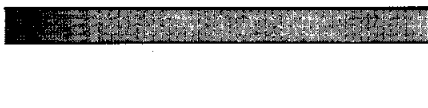

DATA PRESETTER	
PROGRAM	(ON / OFF)
PITCH	(ON / OFF)
CONTROL 1	(ON / OFF)
CONTROL 2	(ON / OFF)
CHANNEL FILTER	
OMNI:	(ON) / OFF
1	2
3	4
5	6
7	8
9	10
11	12
13	14
15	16
MESSAGE FILTER	
NOTE OFF	(ON) / OFF
NOTE ON	(ON) / OFF
POLY A. TOUCH	ON / (OFF)
CONTROL NO.	ALL / *.*.*
PROGRAM CHANGE	ON / (OFF)
CH A. TOUCH	ON / (OFF)
PITCH BEND	ON / (OFF)
CH MODE MES.	ON / (OFF)
SYSTEM MES.	ON / (OFF)
DATA MODIFIER	
0	MSG : 9n, xx, yy
1	LIM : 00 ≤ D ≤ 00
2	:
3	:
4	:
DELAY PROCESSOR	
DELAY TIME	0
OUTPUT ASSIGNER	
OUT-CH ASSIGN	3
OUT-CH OFFSET	0
OUTPORT ASSIGN	1

IDEAS AND SUGGESTIONS



- When synchronizing two or more MIDI sequencers or rhythm programmers, it may be useful to delay one of them. You can do this by setting a processor to accept only System Messages and delaying the output. This will delay Start, Stop, Continue and Timing Clock.
- You recorded a great solo onto a MIDI sequencer using a lot of Pitch Bend, but decide that the Pitch Bend was overdone. You can remove it by setting a processor to accept everything except Pitch Bend, and then feeding the MEP4 output back into the sequencer.
- You are used to playing on a stiff action piano, and when you use a light touch keyboard such as the DX7, the velocity and aftertouch often "bottom out". Simply cut the velocity and/or aftertouch data byte in 1/2 using the Expand modification.
- Super 4-way keyboard split. Using the Limit modification, set each processor to accept a different range of notes. Output each processor on different channels to separate tone generators.
- Turn the DX7 data entry switches (-1/+1) into another type of control change, such as Poly/Mono or Portamento On/Off. (Use the Convert modification.)
- If you don't need a Portamento footswitch, set Portamento Time to 0 and convert the MIDI Portamento On/Off to something else, such as Poly/Mono.
- Convert Channel Aftertouch to Pitch Bend. (But add 40 to the data so you will start from normal pitch.)
- Use the top octave of your keyboard to send Program Change messages! Limit the note number of Note On messages and Convert them into Program Change messages with the original note number as the Program number. If you connect a MIDI cable from a MEP4 OUT back to the MIDI IN of your KX 88, you can even change MEP4 memories by playing a note on your KX88 keyboard. (The KX88 MIDI IN is a MIDI "mixer".)
- Keyboard training game. Notes played too soft or too loud will ring a gong. Use two processors and limit the key velocity.
- Controlling Portamento Time using Channel Aftertouch is effective especially when using fingered portamento. (See DX7 manual.)

-
- Use the Modulation Wheel to send a drum roll (or any repeated note). Convert Modulation Wheel messages into Note On messages for the instrument you want to play. You will need to send one Note Off for each Note On, so use the Step function to convert messages with even numbered data bytes into Off, and odd numbers to On.
 - MIDI Feedback! If you have a device such as the KX88 that will "mix" MIDI messages, you can try feedback echo. Use another MIDI THRU box after the MEP4 output, and send a delayed note back into the MEP4 via the KX88. (THRU box output: one going to the tone generator and one going back to the KX88 MIDI IN.) Decrease the velocity, delay it some more, and send it out again. Set it up so that the loop will continue until the velocity reaches 0. This will require some tricky programming. The fed-back note will have to be on a different channel than the original note, and you will also have to ensure that an equal number of delayed Note Off messages are sent..

There are several possible variants of this technique.

By offsetting the note number, you could create an upward arpeggio for each note played. (When the note number reaches 127 it is no longer fed back).

SPECIFICATIONS

Memories	60 (8K byte)
Switches	GROUP SELECT CURSOR  CURSOR  DEC INC RUN UTILITY EDIT PROCESSOR SELECT 1-4 BYPASS
Display	16 character backlit LCD
Terminals.....	MIDI IN MIDI OUT (x 4) MIDI THRU FOOT SWITCH
Power Consumption.....	10 W
Dimensions.....	480 (W) x 282 (D) x 45.2 (H) mm (18-15/16" x 11-1/8" x 1-3/4")
Weight.....	3.3 kg (7 lbs 4 oz.)

ADDITIONAL INFORMATION

CHARACTER TABLE

	!	"	#	\$	%	&	'	()
*	+	,	-	.	/	0	1	2	3
4	5	6	7	8	9	:	;	<	=
>	?	@	A	B	C	D	E	F	G
H	I	J	K	L	M	N	O	P	Q
R	S	T	U	V	W	X	Y	Z	[
¥]	^	_	`	a	b	c	d	e
f	g	h	i	j	k	l	m	n	o
p	q	r	s	t	u	v	w	x	y
z	{		}	→	←		□	「	」
、	・	ヲ	ア	イ	ウ	エ	オ	ヤ	ユ
ヨ	ツ	ー	ア	イ	ウ	エ	オ	カ	キ
ク	ケ	コ	サ	シ	ス	セ	ソ	タ	チ
ツ	テ	ト	ナ	ニ	ヌ	ネ	ノ	ハ	ヒ
フ	ヘ	ホ	マ	ミ	ム	メ	モ	ヤ	ユ
ヨ	ラ	リ	ル	レ	ロ	ワ	ン	”	□

WHAT'S HEXADECIMAL?

Computers are made up of a huge number of electronic circuits, and an electronic circuit can be in one of two conditions; on or off. This means that computers deal with numbers in a different form than humans normally deal with them.

The Decimal System

The way of counting that we use everyday is called the decimal system, because it has ten numerals, 0 through 9, and is based on the number ten. When we count past 9, we move one place to the left and start over from 1 again, but this "1" means something different than the first "1". You can think of this second numeral as "how many tens", and the third number as "how many hundreds." In other words, each place from right to left represents the number of 10^0 (ones), 10^1 (tens), 10^2 (hundreds), 10^3 (thousands) and so on.

The Binary System

As we mentioned, computers can recognize only two conditions (numerals); on or off (1 or 0). This means that numbers coming into a computer must be made up of ones and zeros. However, if we put enough ones and zeros together, we can express any number we want. This way of counting is called the binary system.

	2^7	2^6	2^5	2^4	2^3	2^2	2^1	2^0	
BINARY	1	0	1	0	1	1	0	1	
DECIMAL	128 + 0 + 32 + 0 + 8 + 4 + 0 + 1								= 173

To find what the binary number 10101101 means in decimal, add up the values of each place.

The Hexadecimal System

Binary numbers are easy for a computer to understand, but troublesome for humans to deal with. So, we use an easy "middle way" called Hexadecimal (often abbreviated "Hex"). This is a number system based on the number sixteen, with sixteen numerals. Since we only have numerals 0 to 9, we will use letters of the alphabet, like this.

0,1,2,3,4,5,6,7,8,9,A,B,C,D,E,F (Hex "F" = Decimal "15")

Then, when we want to go beyond F, we move one place to the left and start with 0 again.

8,9,A,B,C,D,E,F,10,11,...19,1A,1B,1C,1D,1E,1F,20,21....

(So as not to confuse hexadecimal and decimal numbers, a dollar sign "\$" is often added in front of hex numbers. Eg. \$AD)

Here is an example of how to convert a hex number into decimal.

	16^1	16^0	
HEX	A	D	
DECIMAL	16×10	1×13	= 173

The method is the same as when we converted a binary number into decimal.

There is a special reason for using hex when dealing with computers. Computers deal with binary information in groups of 8 bits. (Each 0 or 1 is called a "bit", for Binary digit.) Each group of 8 bits is called a byte. (8 bits = 1 byte) Notice that the left four bits of the binary number in the illustration make the same number as the left digit of the hex number, and the right four bits of the binary number make the same number as the right digit of the hex number.

	2^3	2^2	2^1	2^0	2^3	2^2	2^1	2^0	
BINARY	1	0	1	0	1	1	0	1	
HEX	\$A				\$D				= \$ AD

MIDI sends and receives information using binary computer signals. It is quite easy to convert binary numbers to hex, and hex is easy for us to deal with (only two digits), so in this manual when we refer to MIDI data, we will use hexadecimal numbers.

BINARY, DECIMAL AND HEXADECIMAL CONVERSION

00000000	0	0	01000000	64	40	10000000	160	80	11000000	224	C0
00000001	1	1	01000001	65	41	10000001	161	81	11000001	225	C1
00000010	2	2	01000010	66	42	10000010	162	82	11000010	226	C2
00000011	3	3	01000011	67	43	10000011	163	83	11000011	227	C3
00000100	4	4	01000100	68	44	10000100	164	84	11000100	228	C4
00000101	5	5	01000101	69	45	10000101	165	85	11000101	229	C5
00000110	6	6	01000110	70	46	10000110	166	86	11000110	230	C6
00000111	7	7	01000111	71	47	10000111	167	87	11000111	231	C7
00001000	8	8	01001000	72	48	10001000	168	88	11001000	232	C8
00001001	9	9	01001001	73	49	10001001	169	89	11001001	233	C9
00001010	10	A	01001010	74	4A	10001010	170	8A	11001010	234	CA
00001011	11	B	01001011	75	4B	10001011	171	8B	11001011	235	CB
00001100	12	C	01001100	76	4C	10001100	172	8C	11001100	236	CC
00001101	13	D	01001101	77	4D	10001101	173	8D	11001101	237	CD
00001110	14	E	01001110	78	4E	10001110	174	8E	11001110	238	CE
00001111	15	F	01001111	79	4F	10001111	175	8F	11001111	239	CF
00010000	16	10	01010000	80	50	10010000	176	90	11010000	240	C0
00010001	17	11	01010001	81	51	10010001	177	91	11010001	241	D1
00010010	18	12	01010010	82	52	10010010	178	92	11010010	242	D2
00010011	19	13	01010011	83	53	10010011	179	93	11010011	243	D3
00010100	20	14	01010100	84	54	10010100	180	94	11010100	244	D4
00010101	21	15	01010101	85	55	10010101	181	95	11010101	245	D5
00010110	22	16	01010110	86	56	10010110	182	96	11010110	246	D6
00010111	23	17	01010111	87	57	10010111	183	97	11010111	247	D7
00011000	24	18	01011000	88	58	10011000	184	98	11011000	248	D8
00011001	25	19	01011001	89	59	10011001	185	99	11011001	249	D9
00011010	26	1A	01011010	90	5A	10011010	186	9A	11011010	250	DA
00011011	27	1B	01011011	91	5B	10011011	187	9B	11011011	251	DB
00011100	28	1C	01011100	92	5C	10011100	188	9C	11011100	252	DC
00011101	29	1D	01011101	93	5D	10011101	189	9D	11011101	253	CD
00011110	30	1E	01011110	94	5E	10011110	190	9E	11011110	254	DE
00011111	31	1F	01011111	95	5F	10011111	191	9F	11011111	255	DF
00100000	32	20	01100000	96	60	10100000	192	A0	11100000	256	E0
00100001	33	21	01100001	97	61	10100001	193	A1	11100001	257	E1
00100010	34	22	01100010	98	62	10100010	194	A2	11100010	258	E2
00100011	35	23	01100011	99	63	10100011	195	A3	11100011	259	E3
00100100	36	24	01100100	100	64	10100100	196	A4	11100100	260	E4
00100101	37	25	01100101	101	65	10100101	197	A5	11100101	261	E5
00100110	38	26	01100110	102	66	10100110	198	A6	11100110	262	E6
00100111	39	27	01100111	103	67	10100111	199	A7	11100111	263	E7
00101000	40	28	01101000	104	68	10101000	200	A8	11101000	264	E8
00101001	41	29	01101001	105	69	10101001	201	A9	11101001	265	E9
00101010	42	2A	01101010	106	6A	10101010	202	AA	11101010	266	EA
00101011	43	2B	01101011	107	6B	10101011	203	AB	11101011	267	EB
00101100	44	2C	01101100	108	6C	10101100	204	AC	11101100	268	EC
00101101	45	2D	01101101	109	6D	10101101	205	AD	11101101	269	ED
00101110	46	2E	01101110	110	6E	10101110	206	AE	11101110	270	EE
00101111	47	2F	01101111	111	6F	10101111	207	AF	11101111	271	EF
00110000	48	30	01110000	112	70	10110000	208	B0	11110000	272	F0
00110001	49	31	01110001	113	71	10110001	209	B1	11110001	273	F1
00110010	50	32	01110010	114	72	10110010	210	B2	11110010	274	F2
00110011	51	33	01110011	115	73	10110011	211	B3	11110011	275	F3
00110100	52	34	01110100	116	74	10110100	212	B4	11110100	276	F4
00110101	53	35	01110101	117	75	10110101	213	B5	11110101	277	F5
00110110	54	36	01110110	118	76	10110110	214	B6	11110110	278	F6
00110111	55	37	01110111	119	77	10110111	215	B7	11110111	279	F7
00111000	56	38	01111000	120	78	10111000	216	B8	11111000	280	F8
00111001	57	39	01111001	121	79	10111001	217	B9	11111001	281	F9
00111010	58	3A	01111010	122	7A	10111010	218	BA	11111010	282	FA
00111011	59	3B	01111011	123	7B	10111011	219	BB	11111011	283	FB
00111100	60	3C	01111100	124	7C	10111100	220	BC	11111100	284	FC
00111101	61	3D	01111101	125	7D	10111101	221	BD	11111101	285	FD
00111110	62	3E	01111110	126	7E	10111110	222	BE	11111110	286	FE
00111111	63	3F	01111111	127	7F	10111111	223	BF	11111111	287	FF

WHAT'S MIDI?

Musical Instrument Digital Interface (MIDI) is a way for keyboards, synthesizers, sequencers, rhythm machines, and computers to communicate with each other. Devices that have a MIDI jack can be connected together to send and receive information. Since most musical instrument manufacturers have agreed on MIDI, you can connect devices of various manufacturers.

Each piece of information is called a MIDI MESSAGE. Each MIDI message is made up of 1 to 3 bytes (numbers); a Status Byte and 0,1 or 2 Data Bytes.

The typical MIDI message is in the following form.

Sn. xx. yy

s = Status (8–E)
n = Channel number (0-F indicates channel 1-16)
xx = First data byte (00-7F)
yy = Second data byte (00-7F)

Let's look at a sample 3-byte MIDI message.

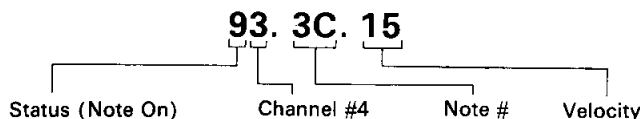

For example, if a DX7 synthesizer receives this message, it does the following.

1. Checks the channel number to see if it is acceptable. If the DX7 has been set to receive that channel, it goes on to the next step. If not, the message is ignored. In the example above, the channel number is 4. (We count 0-F as 1 to 16.)
2. Checks the status. In this case, the status is Note On, so the DX7 knows to expect two more data bytes; note number (what note) and velocity (how hard it was hit).
3. Reads the data bytes and produces the correct note with the correct velocity. (Keep in mind that all this takes only a very short time. It takes about 1/1000 second to send a MIDI message. To us, it seems that the sound was produced at the same time we pressed the key.)

Some MIDI messages have only two bytes; a status byte and a data byte.
For example,

C3. 05

is a Program Change message on channel 4, telling the receiving device to switch to program number 6.

MIDI messages with a status byte from F0 to FF have no channel number. They are called System messages, and are received by all devices regardless of their channel setting.

For an explanation of each type of message, see the MIDI Format Table on p.67.

MIDI FORMAT TABLE

MIDI MESSAGE CATEGORIES				
CHANNEL MESSAGE	Note Off	8n	Note Number	Velocity
	Note On	9n	"	"
	Polyphonic Aftertouch	An	"	Pressure
	Control Change	Bn	(Control Number)	Data
			01 Modulation Wheel	"
			02 Breath Controller	"
			04 Foot Controller	"
			05 Portamento Time	"
			06 Data Entry Slider	"
			07 Main Volume	"
40 Sustain			} 00: Off 7F: On	
41 Portamento				
42 Sostenuto				
43 Soft				
60 Data Increment	7F			
61 Data Decrement	7F			
7A Local	00: Off, 7F:On			
7B All Note Off	00			
7C Omni Off	00			
7D Omni On	00			
7E Mono On	00-0A (Number of channels)			
7F Poly On	00			
Program Change	Cn	Program number		
Channel Aftertouch	Dn	Pressure		
Pitch Wheel	En	LSB	MSB	
COMMON MESSAGE	System Exclusive	F0	Mfgr. ID code	(???)
		F1		
	Song Position Pointer	F2	LSB	MSB
	Song Select	F3	Song number	
		F4, F5		
	Tune Request	F6		
	End Of Exclusive	F7		
REALTIME MESSAGE	Timing Clock	F8		
		F9		
	Start	FA		
	Continue	FB		
	Stop	FC		
		FD		
	Active Sensing	FE		
	System Reset	FF		

-
- 8n Note Off:** The note number indicates which key was released, and velocity indicates how quickly it was released. Very few keyboards have Release Velocity Sensitivity (The Sequential Circuits Prophet T8 is one). Most other keyboards (such as the Yamaha DX series) send a Note On message with a velocity of 0 to indicate a Note Off.
- 9n Note On:** The note number indicates which key was pressed, and velocity indicates how hard it was hit. On keyboards which do not have a velocity sensitive keyboard (such as the DX21), a medium value of 40 is sent. A Note On message with a velocity of 0 is the same as a Note Off message.
- An Polyphonic Aftertouch:** The note number indicates which key is being pressed, and pressure indicates how hard that key is being pressed. (I.e. each key can send independent aftertouch messages.)
- Bn Control Change:** The control number indicates which controller is being moved, and the data indicates the position of the controller. In this chart, control changes 01-07 are "continuous controllers." (Slider or wheel-type controllers) They carry data in the range of 00-7F. Control changes 40-43 are on/off switch-type controllers, and carry data of either 0 or 7F. Control changes 7A-7F are a special type of control change called Mode Messages, and usually carry a fixed data byte. They tell the receiving tone generator how to behave. The way in which these message are interpreted will depend on the device. (See the MIDI Implementation Chart for your tone generator or synthesizer.)
- Cn Program Change:** This tells the receiving device to switch programs (memories).
- Dn Channel Aftertouch:** Also called "Common Aftertouch", this is found on the DX7.
- En Pitch Wheel :** To provide finer resolution, this data is sent in two bytes, first the Least Significant Byte (LSB) and then the Most Significant Byte (MSB). Yamaha tone generators and synthesizers ignore the LSB.
- F0 System Exclusive:** After F0 must come an identification number which has been assigned to each manufacturer. Yamaha's number is 43. What comes between this message and F7 (End of Exclusive)is completely up to each manufacturer (but each byte must be between 0 and 7F). Yamaha uses System Exclusive messages to transmit voice data, sequence data, rhythm pattern data, bulk memory data of all kinds, and many other useful things. See the System Exclusive format chart for your device.
- F7 End Of Exclusive: (EOX)** This marks the end of a System Exclusive message.

F2,F3,F8,FA,FB,FC,FF: Song Position Pointer, Song Select, Timing Clock, Start, Stop, Continue, System Reset are all for controlling sequencers and rhythm machines. See the MIDI Implementation Chart for your device.

FE Active Sensing: If there are no MIDI messages that have to be sent, one of these is sent every 300 msec just to let the receiving devices know that there is still someone out there. If there have not been any MIDI messages for a long time (like 1/2 a second), the receiving device assumes that some error has taken place (eg. a MIDI cable was pulled out by mistake) and will stop all notes.

F1, F4, F5, F9, FD: These are unused, and reserved for future expansion.

SYSTEM EXCLUSIVE DATA FORMAT

RECEPTION DATA

In addition to MIDI messages to be processed, the MEP4 receives two types of System Exclusive message.

1. 60 Memory Bulk Data

Status	F0
ID	43
Sub-status/Device no.	0n (n=device number 0-F)
Format no.	7E
2Kbyte data blocks x 8 (see below)	
EOX	F7

The MEP4 has 8 Kbytes of memory. When this is converted into ASCII, it takes up 16 Kbytes, so the above data is sent in eight 2 Kbyte blocks. The format is the same as above except that the byte count is 10 0A (2058 byte decimal). There must be an interval of at least 100 msec between each block of "header. ASCII data, check sum". After 8 of these blocks have been sent, F7 (EOX) is sent. Each block of data has the following format;

Byte count	10 0A (2 bytes 14 bits)
Header	'L'M'-'-8'9'6'9'-'- (ASCII data)
ASCII data (2058 bytes)
Check sum	?? (one byte)
100 msec interval (to allow the MEP to process the data)	

2. Dump Request

Status	F0
ID	43
Sub-status/Device no.	2n (n = device number 0-F)
Format no.	7E
EOX	F7

TRANSMISSION DATA

When the MEP4 receives a dump request as above with the appropriate device number, it will transmit Memory Bulk data as in the same format described in 1. The dump request message itself will not be sent.

Function ...	Transmitted after received	Transmitted by memory change	Recognized as message for MEP4
Basic Default	1 - 16 X1,X2	1 - 16 X1	1 - 16 X1
Channel Changed	1 - 16	1 - 16	1 - 16
Mode Default Messages	POLY, MONO XG OMNION, OMNIOFF	POLY, MONO OMNION, OMNIOFF	x x x
Note Number : True voice	0 - 127 XXXXXXXXXXXXXXXXXX	x XXXXXXXXXXXXXXXXXX	x x
Velocity Note ON	o XA	x	x
Note OFF	o XB	x	x
After Touch Key's Ch's	o XC o XD	x x	x x
Pitch Bender	o XE	o	x
Control Change	0 - 121 o XF	o	x
Prog Change : True #	o 0 - 127 XH XXXXXXXXXXXXXXXXXX	o 0 - 127 XXXXXXXXXXXXXXXXXX	o 0 - 127 0 - 59
System Exclusive	o XI	o X3	o memory data
System : Song Pos	o XI	x	x
: Song Sel	o XI	x	x
Common : Tune	o XI	x	x
System : Clock	o XI	x	x
Real Time : Commands	o XI	x	x
Aux : Local ON/OFF	o XG	o	x
: All Notes OFF	o XG	o	x
Mes- : Active Sense	o XI	x	x
sages: Reset	o XI	x	x
Notes: Received messages are processed and transmitted to MIDI OUT.			
The message XA - XI can be individually enabled to transmit.			
X1 = memorized			
X2 = multi channel may be assigned for receive and transmit.			
X3 = memory data transmitted by panel switch or dump request.			
Mode 1	OMNI ON, POLY	Mode 2	OMNI ON, MONO
Mode 3	OMNI OFF, POLY	Mode 4	OMNI OFF, MONO
			o : Yes
			x : No

IMPORTANT SAFETY AND INSTALLATION INSTRUCTIONS

INFORMATION RELATING TO POSSIBLE PERSONAL INJURY, ELECTRIC SHOCK AND
FIRE HAZARD POSSIBILITIES HAS BEEN INCLUDED IN THIS LIST.

WARNING — When using electronic products, basic precautions should always be followed, including the following:

1. Read all Safety and Installation Instructions, Supplemental Marking and Special Message Section data, and any applicable assembly instructions BEFORE using this product.
2. Check unit weight specifications BEFORE you attempt to move this product.
3. Main power supply verification. Yamaha Digital Musical Instrument products are manufactured specifically for use with the main supply voltage used in the area where they are to be sold. The main supply voltage required by these products is printed on the name plate. For name plate location please refer to the graphic in the Special Message section. If any doubt exists please contact the nearest Yamaha Digital Musical Instrument retailer.
4. Some Yamaha Digital Musical Instrument products utilize external power supplies or adapters. Do NOT connect products of this type to any power supply or adapter other than the type described in the owners manual or as marked on the unit.
5. This product may be equipped with a plug having three prongs or a polarized line plug (one blade wider than the other). If you are unable to insert the plug into the outlet, contact an electrician to have the obsolete outlet replaced. Do NOT defeat the safety purpose of the plug. Yamaha products not having three prong or polarized line plugs incorporate construction methods and designs that do not require line plug polarization.
6. **WARNING** — Do NOT place objects on the power cord or place the unit in a position where any one could walk on, trip over, or roll anything over cords of any kind. An improper installation of this type can create the possibility of a fire hazard and/or personal injury.
7. Environment: Your Yamaha Digital Musical Instrument should be installed away from heat sources such as heat registers and/or other products that produce heat.
8. Ventilation: This product should be installed or positioned in a way that its placement or location does not interfere with proper ventilation.
9. Yamaha Digital Musical Instrument products are frequently incorporated into "Systems" which are assembled on carts, stands or in racks. Utilize only those carts, stands, or racks that have been designed for this purpose and observe all safety precautions supplied with the products. Pay special attention to cautions that relate to proper assembly, heavier units being mounted at the lower levels, load limits, moving instructions, maximum usable height and ventilation.
10. Yamaha Digital Musical Instrument products, either alone or in combination with amplification, headphones, or speakers, may be capable of producing sound levels that could cause permanent hearing loss. Do NOT operate at high volume levels or at a level that is uncomfortable. If you experience any discomfort, ringing in the ears, or suspect any hearing loss, you should consult an audiologist.
11. Do NOT use this product near water or in wet environments. For example, near a swimming pool, spa, in the rain, or in a wet basement.
12. Care should be taken so that objects do not fall, and liquids are not spilled into the enclosure.
13. Yamaha Digital Musical Instrument products should be serviced by a qualified service person when:
 - a. The power supply/power adapter cord or plug has been damaged; or
 - b. Objects have fallen, or liquid has been spilled into the products; or
 - c. The unit has been exposed to rain; or
 - d. The product does not operate, exhibits a marked change in performance; or
 - e. The product has been dropped, or the enclosure of the product has been damaged.
14. When not in use, always turn your Yamaha Digital Musical Instrument equipment "OFF". The power supply cord should be unplugged from the outlet when the equipment is to be left unused for a long period of time. NOTE: In this case, some units may lose some user programmed data. Factory programmed memories will not be affected.
15. Electromagnetic Interference (RFI). Yamaha Digital Musical Instruments utilize digital (high frequency pulse) technology that may adversely affect Radio/TV reception. Please read FCC Information (inside back cover) for additional information.
16. Do NOT attempt to service this product beyond that described in the user maintenance section of the owners manual. All other servicing should be referred to qualified service personnel.

**PLEASE KEEP THIS MANUAL
FOR FUTURE REFERENCE!**

FCC INFORMATION

While the following statements are provided to comply with FCC Regulations in the United States, the corrective measures listed below are applicable world-wide.

This series of Yamaha professional music equipment uses frequencies that appear in the radio frequency range and if installed in the immediate proximity of some types of audio or video devices (within three meters), interference may occur. This series of Yamaha combo equipment have been type tested and found to comply with the specifications set for a class B computing device in accordance with those specifications listed in subpart J of part 15 of the FCC rules. These rules are designed to provide a reasonable measure of protection against such interference. However, this does not guarantee that interference will not occur. If your professional music equipment should be suspected of causing interference with other electronic devices, verification can be made by turning your combo equipment off and on. If the interference continues when your equipment is off, the equipment is not the source of interference. If your equipment does appear to be the source of the interference, you should try to correct the situation by using one or more of the following measures:

Relocate either the equipment or the electronic device that is being affected by the interference. Utilize power outlets for the professional music equipment and the device being affected that are on different branch (circuit breaker or fuse) circuits, or install AC line filters.

In the case of radio or TV interference, relocate the antenna or, if the antenna lead-in is 300 ohm ribbon lead, change the lead-in to co-axial type cable.

If these corrective measures do not produce satisfactory results, please contact your authorized Yamaha professional products dealer for suggestions and/or corrective measures.

If you cannot locate a franchised Yamaha professional products dealer in your general area contact the professional products Service Department, Yamaha Music Corporation, 6600 Orangethorpe Ave., Buena Park, CA 90620, U.S.A.

If for any reason, you should need additional information relating to radio or TV interference, you may find a booklet prepared by the Federal Communications Commission helpful:

"How to Identify and Resolve Radio — TV Interference Problems". This booklet is available from the U.S. Government Printing Office, Washington D.C. 20402 — Stock No. 004-000-00345-4.

YAMAHA

YAMAHA CORPORATION
P.O.Box 1, Hamamatsu, Japan

VD68760 88 04 0.1 R2 CR Printed in Japa